

THE BRITISH CENSUS

J. C. Dewdney



ISSN 0306 - 6142

ISBN 0 86094 070 5

© J. C. Dewdney 1981

Printed in Great Britain by Headley Brothers Ltd The Invicta Press Ashford Kent

CATMOG

(Concepts and Techniques in Modern Geography)

CATMOG has been created to fill a teaching need in the field of quantitative methods in undergraduate geography courses. These texts are admirable guides for the teachers, yet cheap enough for student purchase as the basis of classwork. Each book is written by an author currently working with the technique or concept he describes.

1. An introduction to Markov chain analysis - L. Collins
2. Distance decay in spatial interactions - P.J. Taylor
3. Understanding canonical correlation analysis - D. Clark
4. Some theoretical and applied aspects of spatial interaction shopping models - S. Openshaw
5. An introduction to trend surface analysis - D. Unwin
6. Classification in geography - R.J. Johnston
7. An introduction to factor analytical techniques - J.B. Goddard & A. Kirby
8. Principal components analysis - S. Daultrey
9. Causal inferences from dichotomous variables - N. Davidson
10. Introduction to the use of logit models in geography - N. Wrigley
11. Linear programming: elementary geographical applications of the transportation problem - A. Hay
12. An introduction to quadrat analysis - R.W. Thomas
13. An introduction to time-geography - N.J. Thrift
14. An introduction to graph theoretical methods in geography - K.J. Tinkler
15. Linear regression in geography - R. Ferguson
16. Probability surface mapping. An introduction with examples and Fortran programs - N. Wrigley
17. Sampling methods for geographical research - C. Dixon & B. Leach
18. Questionnaires and interviews in geographical research - C. Dixon & B. Leach
19. Analysis of frequency distributions - V. Gardiner & G. Gardiner
20. Analysis of covariance and comparison of regression lines - J. Silk
21. An introduction to the use of simultaneous-equation regression analysis in geography - D. Todd
22. Transfer function modelling: relationship between time series variables - Pong-wai Lai
23. Stochastic processes in one-dimensional series: an introduction - K.S. Richards
24. Linear programming: the Simplex method with geographical applications - J.E. Killen

Continued on inside back cover

THE BRITISH CENSUS

by

J.C. Dewdney
(University of Durham)

CONTENTS

	page
I INTRODUCTION	3
II DEFINITIONS AND ORIGINS OF THE CENSUS	3
III CENSUS LEGISLATION	5
IV ORGANISATION OF THE CENSUS	7
(i) Census personnel	7
(ii) Census areas	8
(iii) The enumeration	8
V THE CENSUS SCHEDULE	10
VI PROCESSING THE DATA	12
VII THE PUBLISHED DATA	14
(i) Small Area Statistics	14
(ii) The Published Census Volumes	17
BIBLIOGRAPHY	22
APPENDICES	
1. Questions asked in the 1971 census	29
2. Number and types of area for which 1971 census data have been produced	33
3. Standard format of SAS data	34
4. Standard tables of the published County Reports	37
5. Guide to the published volumes of the 1971 census	40
6. Geography of the 1971 census	43

Acknowledgements

The production of this CATMOG was greatly assisted by the wholehearted cooperation of the Office of Population Censuses and Surveys who provided the copyright material in Appendices 2 and 3. Special thanks are due to Mr. C. Denham, Census Division, O.P.C.S., who commented in detail on the draft text. Any remaining errors and omissions are, of course, entirely my own responsibility.

J.C.D.

I INTRODUCTION

The purpose of this booklet is a simple one, namely to explain, as concisely and in as much detail as space allows, the characteristics of the British census and the range and types of census data available to the census user. The discussion is concerned mainly with the most recent census available at the time of writing, that held on the night of 25/26 April 1971, though with some reference back to earlier censuses and forward to the latest census which took place on the night of April 5/6 1981.

Consequently, and in contrast to the majority of the other booklets in the CATMOG series, we are dealing here not with any particular technique or set of techniques but with a specific data set to which many of the techniques described in other CATMOGs may profitably be applied. We are concerned with the entire census operation, including the collection and dissemination of census results as well as with the nature of the data themselves which, incidentally, form one of the largest data sets likely to be encountered by the student of British geography.

II DEFINITIONS AND ORIGINS OF THE CENSUS

The term 'census' has been used in a variety of ways and has in fact often been applied to non-demographic data, for example the 'census of manufacturing' or the 'agricultural census', so that the term 'population census' is sometimes used for greater clarity. Throughout this booklet, the word 'population' is taken as read, in line with the *Concise Oxford Dictionary* definition of the census as "an official numbering of population with various statistics".

By this definition, censuses have an extremely long history extending over hundreds if not thousands of years. Most early counts (or enumerations) of population, however, were carried out with some specific purpose in mind - most commonly for military conscription or for taxation purposes - were often incomplete and were rarely 'published'. We are concerned only with the modern census, which has been defined (United Nations, 1967) as the total process of collection, compiling, evaluating, analysing and publishing demographic, economic and social data pertaining, at a specified time, to all persons in a country or in a well-delimited part of a country". Thus the concept of the modern census implies an official governmental activity, a comprehensive coverage of the entire population and a set of data referring to a specific point in time. Implicit in the last of these characteristics is the idea that a census should be one of a regular series, though many countries have not yet achieved this desirable situation.

The modern census also involves much more than a mere counting of heads and publication of total numbers; it implies in addition the collection and publication of a wide variety of information on the characteristics or 'attributes' of the individual, such as age, sex, marital status, economic activity, birth-place and many others, classified in many different ways. Thus defined, the modern census is essentially a phenomenon of the nineteenth

and twentieth centuries. Although a few small European states - Iceland and Sweden, for example - had censuses in the eighteenth century, the first modern census of a large population was that of the infant United States, held in 1790, followed by the first British and French censuses, held in 1801. Since the latter date, British censuses have been held at regular ten-yearly (decennial) intervals, the only deviations from this pattern being the absence of a 1941 census, due to the Second World War, and the experiment of a 10 per cent 'sample census' (a contradiction in terms according to the United Nations' definition quoted above) in 1966; a full 1976 census, though with only samples of respondents being asked some of the questions, was at an advanced stage of preparation when it was cancelled (in 1975) on grounds of economy. Thus Britain has one of the world's longest series of regular decennial censuses - eighteen in all - a situation contrasting strongly with many of the less developed countries, which did not have their first censuses until the 1950s or 1960s. Indeed, there remain a handful of countries where the first full census has yet to be held.

With the passage of time, the range of information collected and published in British censuses has progressively expanded. The first four censuses (1801, 1811, 1821, 1831) recorded the number of males and females in each house and family (Benjamin 1968), with a simple occupational breakdown into five classes: agriculture, trade, manufacturing, handicrafts and 'others'. An age question was added in 1821 but at first was not compulsory. The 1841 census involved several innovations which have remained in force to the present day. Enumeration was now carried out by households and the completion of the census form or 'schedule' became the responsibility of the head of household, assisted where necessary by the enumerator. The local administration of the census operation passed from the parish overseer to the local Registrar of Births, Marriages and Deaths, a functionary whose appointment resulted from the establishment of vital registration in England and Wales in 1837. (In Scotland, vital registration did not begin until 1855 and the 1841 and 1851 censuses were carried out by the official schoolmaster or 'other fit person' in each parish). It was not until 1861 that the census of the whole of Great Britain had a common organisation of enumerators responsible to local Registrars, who in turn reported to the Registrars-General of England and Wales and of Scotland. From 1841 onwards, each enumerator recorded the details from the census schedule in an 'enumerator's book' from which census results could be tabulated for publication. Confidentiality of these books is preserved for 100 years; those of 1841-1871 have now been released and provide invaluable source material for detailed studies of the social and demographic structures of nineteenth-century communities (Lawton, 1978; Woods, 1979; Wrigley, 1972). Nowadays, enumerators' books contain only a minimal amount of data, namely the head counts used in the preparation of the Preliminary Report (see below, Section VII (ii)). This has been the case since 1911, when punched cards were introduced for the recording of census data.

Additional information continued to be sought by successive censuses. That of 1851 was the most detailed thus far, with questions on age, sex, marital condition, relationship to the head of household, occupation and birthplace. In 1891 a question on the number of rooms in each household was added and the working population was divided into employers, employees and self-employed.

The value of nineteenth-century British censuses is somewhat reduced by the problem of the several changes which occurred in the areal units used for the recording and publication of data. In 1801, 1811, 1821 and 1831, information, though collected at the parish level, was published only for ancient geographical counties (some data for these years was subsequently made available for registration districts); from 1841 onwards there was a hierarchical system of registration counties (which did not coincide with the ancient geographical counties), registration districts and sub-districts, and it was not until 1911 that the system was altered to one based on Local Authority Areas (LAAs), i.e. Counties, County Boroughs, Municipal Boroughs, Urban Districts and Rural Districts. (In Scotland, Counties, Cities, Large Burghs, Small Burghs and Districts). LAAs (along with their subdivisions - wards in urban areas, Civil Parishes in rural areas) remained in use until 1971. Changes in the boundaries of LAAs continue to present problems but these can usually be overcome, at least as regards total population, by reference to the tables in the published census volumes which record, in minute detail, the boundary changes which have taken place since the previous census and the number of people affected. The major change in the system of Local Authority Areas which took place in England and Wales in 1974 and in Scotland in 1975 necessitated the publication of two sets of volumes of 1971 census results, one in which data are aggregated to 1971 LAAs and a second in which they were aggregated to the new units (see Section VII (ii)).

Subsequent censuses added relatively little to the range of questions asked. Information on fertility of married women was obtained in 1911, 1951 and 1961, on place of work in 1921, 1951 and 1961. All censuses have been on a *de facto* basis, that is each person was enumerated at the place where he was found at the time of the census, but in 1931 and subsequently he was asked also for his 'usual address'. The amount of information collected on migratory movement has varied considerably. A place-of-birth question has been asked in every census since 1841 but the areal framework for which such data have been published has fluctuated between LAA, County and country. In 1961, for the first time, a question was asked concerning place of residence one year prior to the census and in 1966 and 1971 place of residence one year ago and five years ago were both required. The 1971 census is discussed in much greater detail in subsequent sections of this booklet.

III CENSUS LEGISLATION

In Britain, as in most countries, the census is compulsory and is backed by the force of law. In 1971, failure to comply with the census regulations could result in a fine of up to £50. From 1801 to 1911, each census required a new Act of Parliament, but the 1921 and subsequent censuses have all been carried out under the provisions of the Census Act, 1920, the most important of which are as follows:

(i) The Act authorises the taking of censuses of population under the direction and control of the Minister of Health (in 1971 the Secretary of State for Social Services) and permits him to allot the responsibility of carrying out the census to the Registrars-General of England and Wales, Scotland, and Northern Ireland. By agreement, the appropriate authorities in the Isle of Man and the Channel Islands, which are not part of the United Kingdom, carry out a census at the same time. Thus the modern 'British'

census covers the whole of the British Isles with the significant exception of the Irish Republic, which is now, of course, wholly independent. An Irish census was in fact held in April 1971, though on a different date from the British, but Irish censuses have not always coincided with those of the U.K. and the most recent census of the Republic took place in 1979.

For the 1971 and subsequent censuses, England and Wales have been under the control of a new body, the Office of Population Censuses and Surveys (OPCS). The three Registrars-General - of England and Wales, Scotland and Northern Ireland - and their Offices continue to have equal standing in census matters and co-ordinate their work with OPCS through committees and other means, whereas OPCS often takes the initiative in matters relating to Great Britain or the U.K. as a whole. The authorities of the Channel Islands and the Isle of Man liaise with the other Census Offices separately from the main co-ordinating committees. These contacts are designed to ensure that the same range of data is collected in each political unit and that their various publications are organised along similar lines. Nevertheless, many data are published separately for England and Wales, Scotland, Northern Ireland, the Isle of Man and the Channel Islands respectively and only a minority of volumes deal with Great Britain or the United Kingdom (see Appendix) and there remain a number of differences between the publications for the various political units which can present problems to the census user interested in analysing data for the U.K., or even Great Britain as a whole.

(ii) The Act empowers the bodies concerned to hold censuses at intervals of not less than five years' (no maximum inter-censal period is stated). Thus no new Act of Parliament is required to carry out a census once five years have elapsed since the previous one, and each census since 1921 has been directed by an Order in Council.

(iii) The Order in Council prescribes the questions to be asked but, under the terms of the 1920 Act, these must fall within the scope of the following topics:

- (a) Name, sex, age
- (b) Occupation, profession, trade or employment
- (c) Nationality, race, birthplace, language
- (d) Place of abode, character of dwelling
- (e) Condition as to marriage, relation to head of family, issue born in marriage
- (f) 'Any other matter with respect to which it is desirable to obtain statistical information with a view to ascertaining the social or civil conditions of the population'

While this last provision might appear to give the census authorities *carte blanche* to ask any question whatsoever, the phrase 'social or civil conditions' is held to have a limited scope and any question proposed under this category requires an affirmative resolution in Parliament. In practice, Parliament looks at all census proposals. Ministers examine all proposals before they are put to Parliament as a draft Census Order; both Houses debate the draft Order and have the opportunity to reject all or part of the proposals or to change them, and to raise other matters concerning the conduct of the census.

For the 1971 census, a draft Order in Council was laid before Parliament on 28 January 1970; it was debated in the Commons on 17 February and in the Lords on 24 February and the Census Order 1970 (S.I. 1970 No. 481) was made on 24 March 1970. The machinery for taking the census, including the form (schedule) to be used in England and Wales, were prescribed in the Census Regulations 1970 (S.I. 1970 No. 776) signed by the Secretary of State for Social Services on 15 May 1970. This was laid before Parliament on 28 May 1970 and came into operation on 15 June 1970. Equivalent regulations were issued for Scotland and Northern Ireland. Preparations for the 1981 census began with the publication of a White Paper (Cmd. 7146) in July 1978, and were completed two years later. The Census Order 1980 (S.I. 1980 No. 702) was laid before Parliament on 20 March 1980, debated in the Lords on 22 April and 6 May 1980 and in the Commons on 29 April 1980, and was made on 21 May 1980. Census Regulations 1980 (S.I. 1980 No. 897) was signed on 30 June and came into operation on 31 July 1980.

The close scrutiny given by Parliament to all aspects of the census operation ensures that public opinion has a strong influence on the nature of the census, particularly as regards the questions to be asked. The 1978 White Paper relating to the 1981 census proposed the inclusion, for the first time, of an 'ethnic' question: this provoked a vigorous debate in the press and in Parliament and was eventually abandoned. In addition to these restraints, the census authorities are obliged to preserve the strict confidentiality of all information collected, in the sense that no data may be released to any census user - which applies to other government departments as well as to local government officials, private individuals and organisations - in such a way that it would reveal the characteristics of an identifiable individual person or household. All published data are subject to 'confidentiality restraints', described in detail later, which have a considerable effect on the nature of the data released to the census user. Confidentiality is maintained for 100 years, after which the original schedules may be consulted; thus research workers are now allowed full access to the original data only for 1871 and earlier censuses.

IV ORGANISATION OF THE CENSUS

Some knowledge of the procedures involved in the collection of census data is necessary for a full understanding of the results.

(i) Census personnel

In Great Britain, for the 1971 census, there was a three-tier hierarchy of personnel concerned with carrying out the census operation. This comprised: (a) Census Supervisors, about 110 in number, each responsible for an area, defined by Local Authority boundaries, containing a population of nearly 500 000. These were employed full time for a period of ten months (September 1970 to June 1971) and were responsible for the recruitment and training of (b) Census Officers, numbering 2384, who in turn recruited and trained some 6500 Assistant Census Officers and (c) Enumerators. These numbered 111 877 and were responsible for the fieldwork connected with the census. (In a minority of cases, one Enumerator was responsible for more than one Enumeration District; consequently the number of enumerators does not exactly match the number of districts shown in Appendix 2). Thus more than 120 000 people

were employed, for varying lengths of time, in the conduct of the census in Great Britain.

(ii) Census areas

Although the details of organisation were somewhat different in England and Wales and in Scotland respectively, the post and role of Enumerators were common to both political divisions. Great Britain was divided into 125 475 Enumeration Districts (EDs), which were subdivisions of Local Authority Areas (LAAs) so that ED data could be aggregated to provide data for LAAs at all levels (see Appendix 2). On average, therefore, an ED had an area of about 1.8 km² and a population of about 430 distributed among some 145 households. In practice the size of an ED and the number of people and households which it contained varied a great deal according to local conditions of population distribution, with a tendency towards large EDs with small populations in rural areas and small EDs with large populations in urban areas. Thus the average area of an ED in Scotland was 5 km² as against 1.4 in England and Wales, while the average ED populations were 329 and 443 respectively, these figures in turn masking major regional variations. The average ED contained about 150 households in towns, 50 or less in rural areas. Whatever its area or population size, the ED formed the basic data block from which data for all larger areas were eventually assembled. Inevitably, the pattern of ED boundaries changes from one census to the next in response to inter-censal shifts in population distribution. The construction of a new housing estate in a formerly rural ED, for example, may raise the population of that ED above the size which can be allocated to a single enumerator; conversely, slum clearance and non-residential redevelopment in an urban area can reduce the population of an ED to a very low level. It is estimated that between 25 and 40 per cent of 1981 EDs will be different from those used in 1971 though, wherever possible, new EDs will be either aggregates or subdivisions of old ones (Denham, 1980).

In the 1961 census (in part) and the 1966 sample census, the ED was the smallest territorial unit for which data were made available to the census user. The 1971 census, however, involved a major innovation, namely the geo-coding of the census schedules and the eventual release of data on a grid-square basis (see Section VII (i)).

(iii) The Enumeration

As already stated, the modern census refers to a specific point in time; for the British census of 1971 this was midnight on the night of 25/26 April. Another basic feature of the British census is that it is recorded on a *de facto* basis, population being enumerated where it is found on census night. The process of enumeration was the responsibility of the Enumerator whose tasks, extending over a period of four or five weeks, were as follows:

(a) In advance of the date of the census, the Enumerator was required to identify and list, within his ED, all buildings, those buildings or parts of buildings which were dwellings and, within each dwelling, each individual household. In British censuses, the household is the basic unit of enumeration, a fact which draws our attention to a fundamental aspect, and a major problem, of the entire census operation, namely the necessity to establish precise definitions of terms which can then be used consistently by all Enumerators throughout the entire country. Indeed, the establishment of

definitions of all kinds is one of the most important tasks which has to be carried out by the census authorities in the pre-census period. Clearly, the accuracy of the census results and their comparability from one area to another depend on nation-wide consistency in the application of these definitions during the collection of the data and in the publication of the results. To give some idea of the precision involved, it is worth reproducing here the definition of the basic 'household' unit (OPCS 1976):

Private Household: 'A household is either one person living alone or a group of persons (who may or may not be related) living at the same address with common housekeeping. Persons staying temporarily with the household are included. A boarder having at least one meal a day with the household (breakfast is classed as a meal for census purposes) is included with that household. A lodger taking no meals with the household is classed as a separate one-person household even if he shares kitchen and bathroom'.

Non-private household (establishment): 'These are hotels (which term covers boarding houses and holiday camps), hospitals, residential schools and colleges, prisons, defence establishments, ships, religious communities, etc. The distinguishing characteristic of a non-private establishment is some form of communal catering, but households enumerated on H forms (i.e. the special schedule used for private households) with whom there were five or more boarders, patients, foster-children, lodgers or non-domestic employees on census night were converted to the appropriate class of non-private establishments. Households occupying private residences in the grounds of hospitals, schools, etc. and those occupying married quarters within the perimeter of a defence establishment were counted as private households, as were persons living in caravans who were part of a larger establishment but who provided their own catering arrangements (e.g. fairground or circus families), but households occupying flats or suites of rooms within the main buildings of an establishment were not required to be identified separately from the establishment'.

On this basis, in Great Britain in 1971, 97.0 per cent of the population (52 346 800 out of 53 978 540) were in private households, and the bulk of the 'household' data (see Section VII (i)) refer only to this category.

(b) Having identified all households, both private and non-private, within his ED, the Enumerator was then required to deliver to each household, some 2-3 weeks before census date, a leaflet explaining the nature and purpose of the census and indicating what would be required of each household.

(c) The Enumerator's next task was to deliver the census form or 'schedule' to each household within a period of ten to three days before census date. There were different schedules for private and non-private households respectively, and slight differences between the schedules for England, Wales, Scotland, Northern Ireland, the Isle of Man and the Channel Islands.

In 1971, all households in each country received identical schedules, but this has not always been the case. In 1961, for example, it was decided to ask only a small number of questions of every household and to administer the full range of questions only to a ten per cent sample of households. The

Enumerator was provided with packs consisting of a mixture of sample and non-sample schedules ordered in such a way that, starting from the top of the pack, sample schedules asking the full range of questions occurred in the xth, x + 10th, x + 20th, etc. positions, where x was a random number less than 10. He was instructed to proceed round his ED in an orderly way, handing out schedules consistently from the top of the pack. The cases for and against this method of 'sampling in enumeration' are discussed at some length by Benjamin (1970), who concluded that the sampling error involved was not serious. Nevertheless, the method was not repeated in 1971; the full range of questions was put to all households and sample statistics (see Section VII (i)) were prepared by sampling from the completed schedules.

(d) Schedules were collected by the Enumerator during the three days following the census. Having collected the schedules, he was responsible for checking each one for omissions and inconsistencies, making return visits to errant households where necessary.

(e) Finally, the Enumerator had to enter on each schedule the name and full postal address of the household, details of accommodation shared with other households, code numbers for the household, ED and Census District and a six-figure grid reference enabling the household to be allocated to the appropriate 100-metre or 1-kilometre grid square. Work had to be completed and all schedules returned to the appropriate Census Officer within two weeks of census date.

Clearly, the completeness and accuracy of the census results depended heavily on the care and conscientiousness with which the enumerator carried out these tasks.

V THE CENSUS SCHEDULE

A full list of the questions asked in 1971 of all private households in England is given in Appendix 1 and gives an impression of the range and complexity of the information collected in the modern British census.

Among these questions, there is a major distinction between those in Part A, which apply to household accommodation and, although they deal with the conditions under which the population lives, are not strictly 'population' questions at all, and the questions in Part B, which seek information regarding each individual in the household. Questions dealing with household tenure, accommodation and amenities have become a traditional part of the British census and are of particular interest to the social geographer and the planner. In effect, a housing census is carried out simultaneously with and as part of the population census. Given that the household is, in any case, the basic unit of enumeration and must be identified in preparation for the population census, this appears very logical. As Benjamin (1970) points out, this enables housing data to be classified in relation to the characteristics of the population accommodated in the dwelling units' and at the same time 'it makes it possible to classify the population in relation to their housing'.

The questions in Part B relate to the attributes of each individual and clearly fall within any definition of a population census though few outside the U.K. cover so wide a range.

In addition to this distinction between Parts A and B of the schedule, the questions themselves are of several different types. The simplest are those to be answered by the 'tick box' method (A1, A2, A5, B7, B9a, B13, B17). In these instances, the answers to the questions are self-classificatory; the household or individual is allocated to one of a set of pre-determined categories by the person who fills in the schedule for all members of the household. This is usually the 'head of household' but may be any individual in the household if its members do not wish any one person to be considered its 'head'. (There are special arrangements for individuals who do not wish to communicate via the head of household: they are provided with separate schedules and the information transferred to the main household schedule by the Enumerator). The answers to tick-box questions are usually unequivocal, though even these may be incorrect if the wrong boxes or more than one of a set of alternatives are ticked.

A few other questions require only very simple numerical answers, for example 'number of rooms' (A3) or 'number of cars and vans' (A4) and it is a relatively straightforward matter to allocate the answers to a predetermined set of numerical classes. Correct answers, however, depend on careful adherence to the definitions set out on the schedule, as for example in the definition of a room given under question A3.

Most of the questions on the schedule, however, require individual statements, for example: date of birth (B2), relationship to head of household (B5) or occupation (B16), and here the possibilities of error, either accidental or, as sometimes with B2 or B5, intentional, are much greater. In this set of questions, too, problems of definition are often considerable, and the schedule is accompanied by a set of notes (additional to the material reproduced in Appendix 1) to assist the respondent. These notes are too voluminous to be reproduced here and a couple of examples must suffice.

Question B7 asks 'did the person have a job last week?', which requires a definition of the word 'job', which is given in the notes as follows:

- 'A job means any work for payment or profit. In particular it includes:
- (a) work on a person's own account
 - (b) part-time work, even if only for a few hours, such as jobbing gardening or paid domestic work
 - (c) casual or temporary work of any kind (for example seasonal work, weekend work or vacation work by students)
 - (d) unpaid work in a family business, for example a shop or farm
- Unpaid work other than in a family business does not count as a job'.

Question B15 asks for the employer's name and business, and the accompanying note states that the respondent should

'describe the business fully and try to avoid abbreviations or initials. General terms such as 'manufacturer', 'merchant',... 'engineering' are not enough by themselves and further details should be given about the article manufactured or dealt in'.

Similarly, the notes to question B16 ('what was the person's occupation?') state that

"full and precise details of occupation are required...Terms such as

'scientist', 'engineer', 'foreman' should not be used by themselves. Greater detail is required, as for example 'woodworking machinist', 'civil engineer', 'tool-room foreman'.

A further general point concerning questions in this third category is that they are not self-classificatory: they do not automatically allocate the individual to a particular occupation or other group. This operation must be carried out by the census authorities in the period between their receipt of the schedules and the publication of the census results. Vague answers to such questions will swell the numbers in the 'inadequately described' category which appears in some of the published tables.

VI PROCESSING THE DATA

From the discussion so far, it will be clear that a vast amount of processing work is necessary between the collection of the raw data on the census schedules as described in Section V above and the publication of the various types of information described later in this booklet (Section VII). To most census users, the census machinery appears as a 'black box' into which the raw data disappear and from which the published material eventually emerges. A complete knowledge of the processes by which this transformation is achieved is not, perhaps, wholly necessary for the successful use of census material, but there is some justification for at least a general indication of what is involved, if only to emphasise the magnitude of the task which faces the census authorities and to explain the considerable time lapse which usually occurs between census date and the publication of the last set of census data.

In the case of the 1971 census, data-processing involved the coding and punching of the data items recorded on the census schedules for the production of computer tapes carrying the data set from which the many census tabulations were eventually produced. Not all the data were fully coded and stored in this manner. A considerable number of items were used only on a 10% sample basis (see Section VII (i)), the sample being 'selected at random from each run of ten private households, and for one person in ten similarly chosen from those not in private households, for each enumeration district. (This sample was not reselected on a grid square basis)' (OPCS 1977).

Coding and storage involved two sets of operations. Allocation of data to a set of areal units, whether EDs, LAAs or grid squares, depended on the locational references entered on each schedule by the Enumerator; allocation of household and population characteristics to the appropriate classes or categories required coding of the varied information filled in on the schedule by the head of household.

Some idea of the scale of the operation can be obtained from the following simplified data. In 1971, Great Britain as a whole contained 18.2 million private households (England 15.6 m, Wales 0.9 m, Scotland 1.7 m), for each of which at least ten pieces of information (questions A1 - A5) were available from the census schedules. The total population comprised 53.8 million persons (England 45.9 m, Wales 2.7 m, Scotland 5.2 m), for whom at least ten and possibly as many as 24 items were recorded. Thus the complete set of raw census data comprised a total of at least 720 million items

(18.2 m x 10 plus 53.8 m x 10) and probably nearer 1000 million. Following the initial coding and storage of this mass of information, areal aggregation was carried out for EDs, LAAs and a variety of other territorial units (see Appendix 2) and, at a later stage, for grid squares.

Coding was often a complex matter, requiring tricky decisions. In some cases, it is true, the information was already classified by the choice of box ticked by the householder, for example the answers to questions A1, A2, A5, regarding household accommodation, and several of the answers relating to individuals, such as 'job last week' (B7) or 'educational qualifications' (B13). In other cases, coding was a simple matter of allocating individuals to categories which were listed on the schedule and also appeared in the published tabulations, such as 'single', 'married', 'widowed' or 'divorced' (B6). In yet other cases, coding involved the allocation of numerical values from the schedule to numerical classes for tabulation, as with the answers to question A3 (number of rooms) or A4 (number of cars and vans).

There were, however, numerous cases in which the answers on the schedule required transformation during coding. Dates of birth given under question B2, for example, had to be translated into ages at census date and then allocated to age groups; places of birth outside the U.K. (B9b) were grouped by countries or areas. Answers involving the location of individuals required particularly laborious treatment: the answers to the migration questions (B11: 'address one year ago'; B12 'address five years ago') had each to be allocated to the appropriate LAA and were later cross-referenced to produce data on movements between LAAs. The complexity of this operation was the main reason why migration data were processed and published only as a 10% sample.

Still greater complexity was involved in such cases as industrial and occupational data, where the answers to questions B15 and B16 had to be allocated to the appropriate categories of the pre-existing Standard Industrial Classification and Standard Occupational Classification respectively. The answers given to such questions as 'business of the person's employer' or 'description of the actual work done' sometimes proved impossible to allocate, resulting in the residual 'not adequately described' category (some 10 per cent of the total) in these classifications.

In many instances, items appearing in the census tabulations were derived, during computer-processing of the primary coded data, from more than one item on the schedule. The variable 'persons per room', for example, a valuable indicator of pressure on housing resources, involved, for each areal unit, the division of the population present in private households by the total number of rooms in such households. A particularly complex case was that of the 'socio-economic groups' used in numerous published tables (see Section VII (ii)). Individuals were allocated to socio-economic groups not on the basis of their answers to a specific question on the schedule, but by cross-referencing their economic activity and employment status (questions B15, B16, B17). Here again, the complexity of the operation resulted in all tabulations involving socio-economic groups being derived from a 10% sample.

As will be apparent from Section VII below, the published census material is much more than a mere aggregation, for each areal unit, of the answers recorded on the census schedules. It consists for the most part of complex cross-tabulations, for example of persons with households, to give not only

the numbers of households of particular types but also the number of people living in each type of household; or of age and sex to give the number of males or females in each age group. Cross tabulations of the counts for two or more variables is a major part of the work involved in preparing census data for publication and the value of the published material to the census user is vitally dependent on the decisions made by the census authorities, prior to publication date, regarding the number and types of the tables to be published.

VII THE PUBLISHED DATA

The word 'publication' is here used in its broadest sense, to imply all the means by which the census authorities make census data available to the census user. There are two basic forms, of which the more familiar, somewhat simpler and most readily available comprises the published census volumes. These give a wide range of information tabulated for Local Authority Areas and various other types of 'official' territorial divisions. The second are the so-called Small Area Statistics (SAS) which are available on request from OPCS, for which a fee is charged. In addition, special tabulations to the customer's design may be obtained from OPCS or from intermediate agencies such as the SSRC Survey Archive, provided that OPCS has resources for the computation involved.

(i) Small Area (Ward Library) Statistics (SAS)

The basic area for which SAS are made available is the Enumeration District, and data for each ED are produced to the standard format displayed in Appendix 3. This shows the 1971 format; at the time of writing, a provisional format for the publication of 1981 SAS had been prepared, involving 50 tables displayed on eight sheets. Although the 1981 census will be much simpler in terms of questions asked, far more detailed SAS are proposed, with a potential of more than 3000 cells compared with 1571 in 1971. In addition to SAS for EDs, it is possible to obtain data in the same format for administrative divisions at all levels of aggregation and for the various other territorial units displayed in Appendix 2 (both pre- and post-1974/75 local government reorganisation) and separately for England, Wales, England and Wales, Scotland, Great Britain, Northern Ireland and the United Kingdom.

A major innovation in the 1971 census was the geocoding already mentioned, whereby the addition of a grid reference to the census schedule permitted the publication of standard SAS for 100 m (in some areas), 1 km, 10 km and 100 km squares of the National Grid. (The Isle of Man and Channel Islands were not included in this operation). 100 m statistics are available for the whole of Scotland; in England and Wales 100 m coverage is restricted to those areas which had been mapped at 1:2500 or 1:1250 scales by 1971; in all other areas of Great Britain the maximum resolution available is the one-kilometre square.

With reference to all types of SAS data, which form the basic research tool available from the 1971 census, we must return to the matter of confidentiality in published census data. As already indicated, it is a basic rule that no information may be published about an identifiable individual person or household, and in the case of SAS this is catered for by the two processes of 'adjustment' and 'suppression'.

Adjustment is a relatively simple procedure. In the words of the census authorities (OPCS 1976, 1977), referring to the 100% SAS (see below)

'In order to obviate any possibility that the population and household data could be used to derive information about an individual, the final figures have been modified by the addition of a quasi-random pattern of +1, -1, 0 to the individual cells. The sum of adjustments within a single enumeration district/grid square will tend towards zero, as, also will the adjustments to any individual cell when accumulated through a number of enumeration districts/grid squares. Any cell containing a zero will be left unadjusted'.

In the case of 10% SAS (see (d) below) this adjustment is unnecessary but these data, along with all 100% data, are subject to the second procedure, that of 'suppression'.

Suppression means, quite simply, that any statistics from which it might seem to be possible to derive the characteristics of an individual person or household are 'suppressed', that is, they are not released to the census user. (This has the incidental effect of preventing the use of what are likely to be statistically unreliable small numbers). The rules of suppression are complex and can only be understood through a full statement of what is involved. The rules of suppression, which differ as between 100% Population, 100% Household and 10% sample data, are as follows:

(a) In the 100% Population record, all data for areas with fewer than 25 inhabitants are suppressed, with the exception of total population, number of males and number of females. In such cases these three variables are not adjusted, though in unsuppressed squares all population variables suffer adjustment.

(b) In the 100% Household record, all data for areas with fewer than eight households are suppressed, with the single exception of the number of households. This is not adjusted, though in unsuppressed squares all household variables suffer adjustment.

(c) In both these cases, higher level tabulations were obtained by adding together the unadjusted figures from the individual enumeration districts/grid squares. The aggregated figures were then adjusted and were, of course, still subject to suppression.

(d) In the case of 10% sample SAS, suppression rules were as follows:

1. For any area containing only one household in the 10% Sample, all 10% Sample SAS are suppressed.

2. In the case of ED and administrative area data, the suppressed statistics are added to the nearest area with one or more private households in the sample which is also within the same unit of the next highest area of aggregation; for example, suppressed ED data are added to the nearest ED (with one or more private household sampled) in the same civil parish or urban ward.

3. In the case of grid square data, a 'pseudo-square' is created to contain all suppressed data, which can then be added in at the next level

of aggregation. For example, in a set of 100 m squares, a pseudo-100 m square is created, which, added to the appropriate 100 m squares, gives correct totals for a 1 km square, in a set of 1 km squares a pseudo-1 km square is created for inclusion in the 10 km squares, and so on.

The objective of all these procedures is to ensure that, when data are suppressed, a larger geographical unit is created for which SAS can be supplied, and a list of areas cross-referencing suppressed areas to the appropriate 'importing area' is supplied to customers along with their data set.

From this discussion it follows that the SAS supplied by OPCS are neither wholly accurate (owing to adjustment) nor complete for every areal unit (owing to suppression). The inaccuracy resulting from adjustment is, of course, extremely small; indeed it is likely to be smaller than the inevitable errors in the raw census data. The census-user can, however, experience problems as a result of adjustment, particularly if he calculates ratios from adjusted figures, when he may find that the figures for a set of categories (age-groups, occupation groups etc) may sum up to more than 100 per cent of the total population.

The 1971 SAS were suppressed for only a few hundred EDs. In the case of grid squares the results of suppression may at first sight appear much more serious, since it produces large areas for which the full range of data are not available. At the 1 km-square level, for example (CRU/OPCS, 1980), Great Britain contains 147 685 inhabited squares. Of these, only 67 546 have 25 or more inhabitants and most data for the remaining 80 139 (54.3 per cent of all inhabited squares) are suppressed in the 100% Population record. 79 264 (53.7 per cent) are suppressed in the 100% Household record and either 93 221 or 93 532 (63.1-63.3 per cent) are suppressed in the 10% Sample record. However, the suppressed squares (in the 100% Population record) prove to contain only 1.5 per cent of the total population of Great Britain - some 800 000 people - widely scattered throughout the inhabited areas. The problem of suppression is, of course, most serious in sparsely-populated rural areas where squares with fewer than 25 people may be common, and the proportion of the population 'lost' as a result varies considerably from one part of the country to another. In County Durham, for example (Dewdney and Rhind, 1976), which has a relatively high average population density, suppressed squares were 48.5 per cent of all inhabited squares, but the unsuppressed squares contained 99.4 per cent of the County's population.

As Appendix 3 indicates, Small Area Statistics available from the standard format cover a wide range of topics and are of various types. In 1971, the primary division was that into SAS Tables 1-14, which constitute the 100% Population Record; SAS Tables 15-21, which constitute the 100% Household Record; and SAS Tables 22-28, which constitute the 10% Sample Record; the last was subdivided into Record 1 (Tables 22-3) and Record 2 (Tables 23-8). The current draft proposals for 1981 envisage a re-ordering of the material into five sections: PE (100% Population and Employment), HR (100% Households and Residents), H (100% Households), S (10% Sample) for the whole of Great Britain, with additional tables, EW, W, S, for information collected only in England and Wales, Wales and Scotland respectively.

Attention is here confined to the 1971 tables, since these have actually been used, whereas 1981 SAS will not appear until 1982 and their final specification had not been published at the time of writing (August, 1980). The

numbers appearing in the various rows of the standard SAS layouts are numerical 'words' or 'cell numbers'; for example, 100% Population Record cell number 247 in SAS Table 7 is 'the number of single, widowed and divorced men aged 35-39 present in private households on census night'. The use of these cell numbers is clearly essential to computer manipulation of the data, which are stored on magnetic tape for each unit area in the order indicated. (Note that cell numbers 1-31 are reserved for general information of the data set, such as the type of record, the level of aggregation, suppression status and the grid references or other locational indicators of the area to which the data set applies).

The full SAS data set comprises 1571 cells for each unit area; the unsuppressed 1 km inhabited squares in Great Britain, for example, produce a data set of more than 100 million items. (The data set for EDs will be of approximately the same magnitude, since fewer EDs are suppressed). The problems of compacting, storing and accessing such massive data sets have been extensively studied by the Census Research Unit (CRU), Department of Geography, University of Durham (Rhind, 1975; Visvalingam, 1975; Visvalingam and Perry, 1976; Visvalingam, 1977). Full definitions of all terms used, together with a detailed explanation of the layout of all SAS tables have been published by OPCS (1976, 1977).

The dimensions of this CATMOG do not permit a full description of the range of data available from Small Area Statistics; their actual use by the research worker reveals their richness and deficiencies. The great majority of the data are given as simple counts showing, for the area in question, the actual number of persons or households in each category. In a few cases (e.g. Tables 10-14, 18) ratios or proportions are given, but in most instances it is left to the census user to devise his own ratio or other measures for his own needs. The CRU, for example, has prepared a set of 100 'derived' variables considered to be of particular value in the study of the population geography of Great Britain (Rhind, Evans and Dewdney, 1977) and have devised their own measures for mapping and analysis of these variables (Visvalingam, 1976; Visvalingam and Dewdney, 1977).

(ii) The Published Census Volumes

A full set of the published volumes from the 1971 Census of Great Britain comprises nearly 500 separately bound items, containing more than 40 000 pages of tables, and cost well over £1000 at the time of publication.* Lack of space precludes a full listing, which is, however, available from the annual HMSO catalogue, Government Publications for the years 1971-1979 inclusive; the publication programme of OPCS and GRO (Scotland) extended over a period of eight years after census date. An attempt at summarising the list of volumes available appears in Appendices 4 and 5, which also distinguish the various levels of areal coverage.

It is clearly impracticable to provide a detailed statement of the contents of the published volumes and discussion in this section must be

* These figures include the set of about 70 additional volumes in which 1971 data were re-sorted to the new Local Authority Areas established in 1974-75. These were bound in yellow to distinguish them from the volumes containing data on the 1971 areal base, which were bound in the traditional blue covers.

restricted to an indication of the range of data available. From Appendix 5 it will be apparent that this falls into three main categories.,

(a) Preliminary Reports contain provisional data produced as rapidly as possible after the completion of the enumeration. Census 1971 Scotland, Preliminary Report (published in July 1971) and Census 1971 England and Wales, Preliminary Report (pub. August 1971) contained provisional figures of total population for each Local Authority Area, together with equivalent data for 1951 and 1961, and population totals from all previous censuses for the United Kingdom and the component countries. Advance Analyses for Great Britain and for each County of England and Wales, together with the Second Preliminary Report for Scotland (61 volumes in all) appeared within one year of census date: these were based on information transcribed by the enumerator onto sheets marked for direct reading by computer and gave provisional figures for age, sex, marital status and economic situation. The Advance Analyses will not be repeated in the 1981 census, so that publication of the main results can be speeded up.

All data in the Preliminary Reports and Advance Analyses were considered provisional and subject to amendment in the later, definitive publications, as were those in the Census 1971 Great Britain, Summary Tables, 1% Sample volume, published in 1973, which gave a variety of population, economic and household statistics in advance of the definitive volumes on those topics. (A 1% Sample volume is not planned for the 1981 census).

Definitive publications were of two kinds: County Reports and the various 'national' volumes for Great Britain, England and Wales or Scotland, the latter including cases where there was a separate volume for each of the ten 'standard regions'.

(b) County Reports, a full set of which cost nearly £300, constituted about half of the total material published and comprised 215 volumes, one for each of the 37 Counties and Cities of Scotland (plus one for Scottish New Towns) and three (labelled Census 1971 England and Wales County Report Part I, Part II and Part III respectively) for each of the 59 Counties in England and Wales. Each County had a standard set of tables; those produced for English and Welsh counties are indicated in Appendix 4 (there were minor differences in Scotland). As this Appendix shows, Tables 1-18 (Part I in England and Wales) give general information on population numbers by sex, age, marital status, country of birth and employment status ('economic activity'); Tables 19-24 (Part II) give household data, covering size, type of household space and density of occupation; Tables 25-31 (Part III) deal mainly with household tenure and amenities. The material contained in the County Reports is roughly equivalent, though somewhat differently arranged, to that of the 100% Population and 100% Household SAS described earlier. The tables in the 1981 County Reports are being planned to resemble closely those in the 1981 SAS and, unlike the 1971 reports, will include tables of 10% variables.

Appendix 4 also indicates the areal levels at which data are available from the County Reports. While the great majority is given for all LAAs, there are a number of irritating cases where figures for urban administrative divisions with fewer than 50 000 inhabitants and for Rural Districts of whatever size are not provided. (This 'thresholding' of LAAs will be discontinued in the 1981 reports). At the finer areal level of wards and Civil Parishes, the only data published are those in Table 3 - area, population, number of

households and number of rooms - which greatly restricts the amount of analysis which can be carried out at this level using the published volumes.

(c) 'National' volumes

Categorisation and condensed listing of the many published volumes of the 1971 census, as attempted in Appendix 5 presents considerable problems; the main difficulties are as follows:

(a) A variety of territorial units are used as a basis for allocating the data to individual volumes. While some topics are dealt with in a single volume or set of volumes covering the whole of Great Britain, others are covered in separate volumes for England and Wales and for Scotland respectively, in which case the tables presented may differ in detail between the two areas. Furthermore, the England and Wales coverage of some topics is subdivided into individual volumes for each of the nine standard regions. Only very rarely do data for Wales appear in a separate volume.

(b) While much of the material is published on a 100% basis, certain 'difficult to code' items are published only for a 10% sample. A common procedure in the publication of selected items in a 'summary' 100% volume, followed by 10% volumes with a more detailed breakdown. Given the much smaller size of the Scottish population, there are several cases where details are given at the 100% level for that country which appear only at 10% level for England and Wales.

(c) Within each topic a variety of sets of areal units are used for tabulation. Great Britain, Scotland and England and Wales invariably appear; the most common subdivision is into the standard regions of England and Wales, and planning subregions in Scotland, but there are several cases in which data appear at the level of Local Authority Areas.

(d) Confusion can arise as between 'volume', which for this discussion is defined as a separately bound item, and 'Part', a term frequently appearing on the covers. A topic may be divided into several Parts, which are numbered I, II, III, etc., but two or more Parts may be bound in a single volume, while in some cases a large Part is split between two or more volumes which are then labelled Part IIIA, IIIB, IIIC, etc.

Appendix 5 attempts to sort out these complexities and in addition indicates the approximate size of each data set. The division of Appendix 5 into sections A, B1, B2 and topics 1-41 is wholly unofficial and represents only this author's attempt at systematisation.

Appendix 5 lists only those volumes (bound in blue) in which the data were tabulated on the basis of LAAs or other territorial divisions existing at the time of the census in 1971. A brief note at the end of this section indicates the material re-tabulated on the basis of the new LAAs established in England and Wales in 1974 and in Scotland in 1975 and published subsequently in a set of yellow-bound volumes.

A. Preliminary Data (topics 1-6) have already been mentioned above and B1. County Reports (7) have been discussed as the main source of detailed local data, constituting about half of the total published output. Economic Activity data (8) are also published on a County basis but are best considered along with national volumes on that topic.

B2. Data Published on a National Basis are here grouped into six topics (i-vi) and a concluding section (vii) lists a variety of summary and special reports.

(i) Birthplace and Usual Residence data occupy five volumes and more than 1100 pages of tables. Selected 100% data on country of birth for Great Britain as a whole occupy one volume (9). Usual residence is combined with country of birth in a single Scottish volume (12) but appears separately (11) for England and Wales. The great bulk of the material on this topic, however, appears in (10) England and Wales Country of Birth Supplementary Tables where, in two 10% volumes, birthplace is cross-tabulated with household characteristics, migration movements and economic activity. The areal breakdown in these volumes is most commonly to standard regions and their subdivisions, with a few items displayed at Local Authority Area level.

(ii) Housing data (6 vols, 1176 pages). Summary Tables for Great Britain appear in a single volume (13) and there is rather more detailed information in the Scottish Housing Composition Tables (16), but most of the material is in the three-volume England and Wales Housing Tables (14) and the Scottish Housing Report (15). A standard set of a dozen large tables in these volumes cover (England and Wales Pt I) households by number, size, persons per room, tenure and type of household space; (Pts II & III, in one volume) cross-tabulations of amenities with tenure, household size, etc; and (Pt. IV) numbers of households and persons by tenure, type of household space and persons per room. The same topics are covered in the single Scottish volume. The areal units are regions and conurbations in England and Wales, planning sub-regions in Scotland.

(iii) Household data (5 vols, 1246 pages) follow a similar general pattern with a volume of G.B. Summary Tables (17) and more detail in the three England and Wales (18) and one Scottish (19) volume. There are 50 tables altogether based on a 10% sample, subdivided for (England and Wales) into Part I, which classifies households by type, size, number of rooms, persons, dependent children, earners, domestic servants, pensioners, etc; Part II, classifying households by economic activity and socio-economic class, numbers of dependent children and earners, country of birth of the main earner etc; and Part III, which is concerned essentially with the composition of families by household type. Parts I and II tabulate for the whole country and in some cases at region and conurbation level: some tables in Part III come down to Local Authority Areas with populations of 15 000 or more. The Scottish data, at planning sub-region level, are combined in a single volume.

(iv) Economic Activity is recorded in two ways. At the national level there are six volumes, five for Great Britain as a whole (20) and one for Scotland (21). GB Economic Activity Part I comprises one very large 100% table showing economic activity (active/inactive, the latter subdivided into sick, retired, seeking work, etc.) for males, females and married females classified by age, At region, conurbation and subregion levels. Parts II, III, IV and V consist of 36 tables covering, by age and sex, such items as employment status, occupation, industry (both broken down to 200+ Minimum List Headings), changes of occupation, hours worked, socio-economic class and area of usual residence. Part VI carries a selection of data down to smaller areal units. All data in Parts II-VI are 10% but the single Scottish volume records 100%.

In addition, the 59 Economic Activity County Leaflets and the equivalent four Scottish volumes (by groups of planning regions) (8) display similar data at the Local Authority Area level and contain a standard set of four 10% tables cross-tabulating economic activity, occupation, industry, employment status, socio-economic class, usual residence, workplace and sex.

(v) Migration data are the biggest single topic set, comprising a total of 43 volumes, over 6700 pages and more than one-sixth of the total output. Owing to the complex coding involved in matching origins and destinations from the addresses given on the census schedules, the majority of this material is based on a 10% sample of households. The GB Migration Tables (22) number 19 in six volumes with a breakdown to conurbations and regions, while the England and Wales Migration Regional Reports (23) have a standard set of 27 tables which classify one-year and five-year migrants by age, sex, marital condition, place of birth, socio-economic class and other characteristics, down to counties, county boroughs, urban areas of 50 000 or more inhabitants and New Towns. The Scottish Migration Tables (10%), 53 in number, give considerably more detail. All the migration material so far is 10%, but a subsequent 100% volume for Scotland (25) has 18 tables at conurbation and planning sub-region level.

(vi) workplace and Transport to Work data are standard throughout Great Britain though published separately for England and Wales (2 vols - 26) and Scotland (one vol. - 27). Part I deals with residence and workplace; residential population and working population; and changes of workplace by socio-economic class; Part II with the means of transport to work; all to Local Authority Area level.

(vii) Summaries and Special Reports. Grouped together here are some 18 volumes of 3200 pages, which are of three basic types. Some of them summarise certain topics which could be obtained, at the cost of much labour, by extraction from the various County and National volumes already described; others cover topics for the whole of Great Britain not covered elsewhere; and a third group relate to specially selected areas. In the first category are the GB Age, Marital Condition and General Tables (28), GB Persons of Pensionable Age (31), Scotland Population Tables (32) and Population Summary (33), the Wales Summary Tables (40) and the special New Towns volume (39), though several of these give additional information, notably comparisons with earlier censuses. In the second category (topics not covered elsewhere) are the volumes on Non-private Households (29), Qualified Manpower (30,35), Fertility (36,37) and Availability of Cars (38), while the third group comprises the Gaelic Report (34) and the Report on the Welsh Language in Wales (41).

(viii) Data for the new (1974/75) administrative divisions. Comprising 73 volumes with nearly 7000 pages of tables (bound in yellow covers), these were produced as two series:

(a) County and Regional Reports involve one volume for each of the 53 new Counties* of England and Wales and the 9 new Regions of Scotland established in 1974 and 1975 respectively. Each volume contains a uniform set of 25 tables which contain virtually the same material as listed for the old County

* No yellow-bound volume was necessary for Greater London since its boundaries and those of the 32 constituent London Boroughs had been fixed before 1971 and were not altered in the 1974 re-organisation of local government.

Reports in Appendix 4. Six tables (3, 5, 11, 20, 23, 28 in Appendix 4), which were inappropriate to the new LAAs or for which data for the new LAAs could not be assembled, were omitted from the England and Wales volumes and four (19, 22, 26, 27 in Appendix 4) were 'curtailed in non-Metropolitan counties to reduce the size of the published volumes'. In the latter case full tables are available from OPCS for the cost of reproduction. Tables in the yellow volumes for England and Wales are numbered to match those in the earlier County Reports and, with the exception of Tables 1 and 31 which give data at county level only, tabulate on the basis of the new Counties and Districts. In Scotland, where there was some re-arrangement of the tables, a few items are given down to Civil Parish level.

(b) Migration Reports, all on a 10% basis, include one volume for the whole of Great Britain and one each for the ten Standard Regions. The tables are basically the same as those in the earlier Migration Tables and Migration Regional Reports (22, 23, 24 in Appendix 5), with data re-sorted to the new LAAs, an operation which involved re-coding of all addresses in the sample.

As has already been indicated, this discussion can give little more than a glimpse of the richness and diversity of the British census. There are, inevitably, irritating minor deficiencies - items of interest to the individual research worker are not always available, the areal units used may not always be precisely those he requires, above all the cost of obtaining the data may be prohibitive - but no census could possibly satisfy all potential users and the deficiencies are for the most part quite minor ones. Except on the matter of costs - which are part of national financial policy and thus beyond the direct control of the census authorities - adverse criticism is far outweighed by the value of the census as a basic research data source.

BIBLIOGRAPHY

(* denotes a work cited in the text)

A Origin and development of the British census

- *Benjamin, B. (1968). *Demographic analysis*. (Allen and Unwin, London).
- *Benjamin, B. (1970). *The population census*. (Heinemann, London, for S.S.R.C.).
- Brown, A. (1978). Towards a world census. *Population Trends*, 14, 17-20.
- Kelsall, R.K. (1967). *The social structure of modern Britain: population*. (Longman, London).
- *Lawton, R. (ed). (1978). *The census and social structure*. (Cass London)..
- Marsh, D.C. (1965). *The changing social structure of England and Wales*. (Routledge and Kegan Paul, London).
- Office of Population Censuses and Surveys. (1977b). Planning for the 1981 census of population. *Population Trends*, 10, 7-9.

*United Nations. (1967). Principles and recommendations for the 1970 population censuses. *Statistical Papers Series M.44*. (U.N. Statistical Office, New York).

*Woods, R. (1979). *Population analysis in geography*. (Longman, London).

*Wrigley, E.A. (ed). (1972). *Nineteenth-Century society*. (Cambridge University Press).

B Analysis and uses of the census

- Craig, J. (1976). 1971 census grid squares. *Population trends*, 6, 14-15.
- Craig, J. and Webber, R. (1978). *Socio-economic classification of local authority areas*. O.P.C.S. Studies on Medical and Population Subjects No. 35. (H.M.S.O., London).
- *Denham, C. (1980). The geography of the census: 1971 and 1981. *Population Trends*, 19, 6-12.
- Hakim, C. (1977). Census-based area profiles: a review. *Occasional Paper No.2*. (O.P.C.S.).
- Hakim, C. (1978). Census confidentiality, microdata and census analysis. *Occasional Paper No.3*. (O.P.C.S.).
- Hakim, C. (1978). Social and community indicators from the census. *Occasional Paper No.5*. (O.P.C.S.).
- Hakim, C. (1978). Census data and analysis: a selected bibliography. *Occasional Paper No.6*. (O.P.C.S.).
- *Hakim, C. (1978). Data dissemination for the population census. *Occasional Paper No.11*. (O.P.C.S.).
- Hunt, A.J. (1968). Problems of population mapping. *Transactions Institute of British Geographers*, 43, 1-8.
- Jones, E. (1961). Sociological aspects of population mapping in urban areas. *Geography*, 46, 1-8.
- Lawton, R. (1961). The 1961 census of England and Wales. *Geography*, 46, 238-240.
- Leete, R. and Fox, J. (1977). Registrar General's social classes: origins and uses. *Population Trends*, 8, 1-7.
- *Office of Population Censuses and Surveys. (1976). *1971 Census standard small area statistics (Ward Library): explanatory notes*, (O.P.C.S., London).
- *Office of Population Censuses and Surveys. (1977). *1971 Grid square statistics: explanatory notes*. (O.P.C.S., London).

- Office of Population Censuses and Surveys. (1979). Geographical area units. *Population Trends*, 15, 16-21.
- *Rhind, D.W. (1975). Geographical analysis and mapping of the 1971 U.K. census data. *Working Paper No.3*. (Census Research Unit, Department of Geography, University of Durham).
- Rhind, D.W. (1975). Mapping the 1971 census by computer. *Population Trends*, 2, 9-12.
- *Rhind, D.W., Evans, I.S. and Dewdney, J.C. (1977). The derivation of new variables from population census data. *Working Paper No.9*. (Census Research Unit, Department of Geography, University of Durham).
- Robertson, I.M.L. (1969). The census and research: ideals and reality. *Transactions Institute of British Geographers*, 48, 173-187.
- *Visvalingam, M. (1975). Storage of the 1971 U.K. census data: some technical considerations. *Working Paper No.4*. (Census Research Unit, Department of Geography, University of Durham).
- *Visvalingam, M. (1976). Chi-square as an alternative to ratios for statistical mapping and analysis. *Working Paper No.8*. (Census Research Unit, Department of Geography, University of Durham).
- *Visvalingam, M. (1977). A locational index for the 1971 kilometre-square population census data for Great Britain. *Working Paper No.12*. (Census Research Unit, Department of Geography, University of Durham).
- *Visvalingam, M. and Dewdney, J.C. (1977). The effects of the size of areal units on ratio and chi-square mapping. *Working Paper No.10*. (Census Research Unit, Department of Geography, University of Durham).
- *Visvalingam, M. and Perry, B.J. (1976). Storage of the grid-square based 1971 B.G. census data: checking procedures. *Working Paper No.7*. (Census Research Unit, Department of Geography, University of Durham).
- C A sample of works based predominantly on census data
- Barke, M. (1978). Changing journey-to-work patterns in Fife, 1961-1971. *Scottish Geographical Magazine*, 94, 145-158.
- Bowen, E.G. and Carter, H. (1975). The distribution of the Welsh language in 1971. *Geography*, 60, 1-15.
- Carter, H. (1956). Population changes in Wales, 1931 to 1951. *Geography*, 41, 126-129.
- *Census Research Unit/Office of Population Censuses and Surveys. (1980). *People in Britain: A census atlas*. (H.M.S.O., London).

- Champion, A.G. (1976). Evolving patterns of population distribution in England and Wales, 1951-71. *Transactions Institute of British Geographers, New Series* 1, 401-420.
- Clarke, J.I. (1960). Persons per room: an index of population density. *Tijdschrift voor economische en sociale Geografie*, 51, 257-260.
- Clarke, J.I. (1960). Rural and urban sex ratios in England and Wales. *Tijdschrift voor economische en sociale Geografie*, 50, 29-39.
- Clarke, J.I. and Mounsey, H. (1980). Population redistribution and regional policy in Britain, in: Conference on the implications of current demographic trends in the U.K. for social and economic policy. *O.P.C.S. Occasional Paper 19/3*.
- Coates, B.E. (1968). The distribution of the overseas-born population of the British Isles. *Transactions Institute of British Geographers*, 43, 37-43.
- Coates, B. (1974). *Census Atlas of South Yorkshire*. (Department of Geography, University of Sheffield).
- Coates, B.E. and Rawstron, E.M. (1971). *Regional variations in Britain*. (London).
- Coulter, J. (1978). Grid-square census data as a source for the study of deprivation in British conurbations. *Working Paper No. 13*. (Census Research Unit, Department of Geography, University of Durham).
- Craig, J. (1975). *Population density and concentration in Great Britain, 1931, 1951 and 1961*. O.P.C.S. Studies on Medical and Population Subjects, No. 30. (H.M.S.O., London).
- Craig, J. (1977). Densely populated areas. *Population Trends*, 9, 16-19.
- Craig, J. (1979). Population density: changes and patterns. *Population Trends*, 17, 12-16.
- Craig, J. (1980). Comparing counties in England and Wales. *Population Trends*, 19, 22-28.
- Dalton, M. and Seaman, J.M. (1973). The distribution of New Commonwealth immigrants in Ealing, 1961-66. *Transactions Institute of British Geographers*, 58, 21-37.
- Davidson, R.N. (1976). Social deprivation: an analysis of intercensal change. *Transactions Institute of British Geographers, New Series* 1, 108-117.
- Department of the Environment. (1971). *Long-term population distribution in Great Britain: a study*. (H.M.S.O., London).

- Dewdney, J.C. (1955). Changes in population distribution in the county of Fife; 1755-1951. *Scottish Geographical Magazine*, 71, 27-42.
- Dewdney, J.C. (1968). Age structure maps of the British Isles. *Transactions Institute of British Geographers*, 43, 9-18.
- *Dewdney, J.C. and Rhind, D.W. (eds). (1976). *People in Durham: a census atlas*. (University of Durham, Census Research Unit, Department of Geography).
- Humphrys, G. (1968). A map of housing quality in the United Kingdom. *Transactions Institute of British Geographers*, 43, 31-36.
- Humphrys, G. (1974). Inquiry into people: Wales. *Geographical Magazine*, 46, 185-187.
- Johnston, R.J. (1967). A reconnaissance study of population change in Nidderdale 1951-61. *Transactions Institute of British Geographers*, 41, 113-123.
- Jones, H.R. (1965). A study of rural migration in Central Wales. *Transactions Institute of British Geographers*, 37, 31-45.
- Jones, H.R. (1967). Migration within Scotland. *Scottish Geographical Magazine*, 83, 151-160.
- Jones, H.R. (1970). Migration to and from Scotland since 1961. *Transactions Institute of British Geographers*, 48, 145-160.
- Jones, H.R. (1975). A spatial analysis of human fertility in Scotland. *Scottish Geographical Magazine*, 91, 102-114.
- Jones, P.N. (1970). Some aspects of the changing distribution of coloured immigrants in Birmingham. *Transactions Institute of British Geographers*, 50, 199-219.
- Jones, P.N. (1978). The distribution and diffusion of the coloured population in England and Wales, 1961-71. *Transactions Institute of British Geographers, New Series* 3, 515-532.
- Law, C.M. (1967). The growth of urban population in England and Wales, 1801-1911. *Transactions Institute of British Geographers*, 41, 125-143.
- Law, C.M. and Warnes, A.M. (1976). The changing geography of the elderly in England and Wales. *Transactions Institute of British Geographers, New Series* 1, 453-471.
- Lawton, R. (1959). The daily journey to work in England and Wales. *Town Planning Review*, 29, 241-257.
- Lawton, R. (1963). Recent trends in population and housing in England and Wales. *Sociological Review*, 11, 303-321.
- Lawton, R. (1963). The journey to work in England and Wales: forty years of change. *Tijdschrift voor economische en sociale Geografie*, 34, 61-69.
- Lawton, R. (1968). A map of overcrowding in the British Isles. *Transactions Institute of British Geographers*, 43, 19-23.
- Lawton, R. (1968). Population changes in England and Wales in the later nineteenth century: an analysis of trends by registration districts. *Transactions Institute of British Geographers*, 44, 55-74.
- Lawton, R. (1973, 1977). People and work; in: *The U.K. space*, J.W. House (ed). (Weidenfeld and Nicholson, London).
- Lawton, R. (1974). Inquiry into people: England. *Geographical Magazine*, 46, 179-184.
- Mohan, J. (1979). The use of grid-square census data in the location of hospital facilities. *Working Paper No.15*. (Census Research Unit, Department of Geography, University of Durham).
- Morgan, B.S. (1976). The bases of family status segregation: a case study in Exeter. *Transactions Institute of British Geographers, New Series* 1, 83-107.
- Office of Population Censuses and Surveys. (1976). Travelling to work: the 1971 census picture. *Population Trends*, 3, 12-23.
- Peach, G.K.C. (1966). Factors affecting the distribution of West Indians in Great Britain. *Transactions Institute of British Geographers*, 38, 151-163.
- Robertson, I.M.F. (1961). The occupational structure and distribution of rural population in England and Wales. *Scottish Geographical Magazine*, 77, 165-179.
- Robertson, I.M.L. and Wood, M. (1966). A map of the distribution of population in Scotland on census night April 23rd, 1961. *Scottish Geographical Magazine*, 82, 53-54.
- Rosing, K. and Wood, P.A. (1971). *Character of a conurbation: a computer atlas of Birmingham and the Black Country*. (London University Press).
- Rhind, D.W., Stanness, K. and Evans, I.S. (1977). Population distribution in and around selected British cities. *Working Paper No.11*, (Census Research Unit, Department of Geography, University of Durham).
- Saville, J. (1957). *Rural Depopulation in England and Wales*. (Routledge and Kegan Paul, London).
- Shaw, M. (1979). Wolverhampton 1871 and 1971. *Population Trends*, 18, 17-23.

- Soulsby, E.M. (1972). Changing sex ratios in the Scottish border counties. *Scottish Geographical Magazine*, 88, 5-18.
- Storrie, M.C. (1962). The census of Scotland as a source in the historical geography of Islay. *Scottish Geographical Magazine*, 78, 152-165.
- Storrie, M.C. (1968). Household tenure in the British Isles. *Transactions Institute of British Geographers*, 43, 25-30.
- Thomas, J.G. (1957). Distribution of Welsh-born population in England, 1951. *Geography*, 42, 250-253.
- Vaughan, T.D. (1960). Population changes in Northern Ireland. *Geography*, 45, 214-217.
- Vince, S.W.E. (1952). Reflections on the structure and distribution of rural population in England and Wales, 1921-1931. *Transactions Institute of British Geographers*, 18, 53-76.
- Webber, R. (1978). Parliamentary constituencies: a socio-economic classification. *Occasional Paper No.13*. (O.P.C.S.).
- Webber, R. (1978). Which residential neighbourhoods are alike? *Population Trends*, 11, 21-26.
- Webber, W. (1979). Census enumeration districts: a socio-economic classification. *Occasional Paper No.14*. (O.P.C.S.).
- Webber, R. and Craig, J. (1976). Which local authorities are alike? *Population Trends*, 5, 13-19.
- Willatts, E.C. and Newson, M.G.C. (1953). The geographical pattern of population changes in England and Wales, 1921-51. *Geographical Journal*, 119, 431-454.
- Wilson, M.G.A. (1978). A spatial analysis of human fertility in Scotland. *Scottish Geographical Magazine*, 94, 130-143.

In addition to the works cited above, invaluable information and data are available from the following periodical publications:

Population Trends (quarterly journal of the Office of Population Censuses and Surveys) H.M.S.O., London.

O.P.C.S. Occasional Papers, O.P.C.S., London.

O.P.C.S. Monitors, O.P.C.S., London.

Occasional *Papers* and *Monitors* are distributed by the Information Branch, Office of Population Censuses and Surveys, St. Catherine's House, 10, Kingsway, London WC2B 6JP.

Census data should be ordered from: Customer Services Division, Office of Population Censuses and Surveys, Titchfield, Fareham, Hants, PO15 5R.

APPENDIX 1

CENSUS (ENGLAND) 1971

QUESTIONS ASKED OF ALL PRIVATE HOUSEHOLDS

PART A (Questions relating to the household's accommodation)

- A1. How do you and your household occupy your accommodation?
1. As owner occupier (including purchase by mortgage)
 2. By renting it from a Council or New Town
 3. As an unfurnished letting from a private landlord or company or Housing Association.
 4. As a furnished letting
 5. In some other way (Please give details including whether furnished or unfurnished)
- A2. Does your household share with anyone else the use of any room, or hall, passage, landing, or staircase?
- Yes No
- A3. How many rooms are there in your household's accommodation? (Do not count: small kitchens less than 6ft wide; bathrooms and toilets; sculleries not used for cooking; closets, pantries and storerooms; landings, halls, lobbies or recesses; offices or shops used solely for business purposes. A large room divided by a sliding or fixed partition should be counted as two rooms; a room divided by curtains or portable screens should be counted as one room).
- A4. How many cars and vans are normally available for use by you or members of your household (other than visitors)? (Include any provided by employers if normally available for use by you or members of your household, but exclude vans used solely for the carriage of goods).
- A5. Has your household the use of the following amenities on these premises?
- (a) A cooker or cooking stove with an oven
 - (b) A kitchen sink permanently connected to a water supply and a waste pipe
 - (c) A fixed bath or shower permanently connected to a water supply and a waste pipe
 - (d) A hot water supply (to a washbasin, or kitchen sink, or bath, or shower) from a heating appliance or boiler which is connected to a piped water supply.
 - (e) A flush toilet (W.C.) with entrance inside the building
 - (f) A flush toilet (W.C.) with entrance outside the building
- For each of A5 (a) - (f), the following tick boxes are provided:
1. Yes - for use only by this household
 2. Yes - for use also by another household
 3. No

APPENDIX 1 (cont.)

PART B (Questions to be answered by every person present; i.e. by every person who (a) spends Census night 25/26 April 1971 in this household or (b) joins this household on Monday 26 April and has not been included as present on a Census form elsewhere .

- B1. Name and surname
- B2. Date of birth (day, month, year)
- B3. Sex (M or F)
- B4. If the person usually lives here, write 'here'; if not, write the person's usual address (For boarders write 'here' only if they consider this their usual address; for students and children who are away from home during term time give their home address; for persons with no settled address, write 'none')
- B5. Write 'head' for the head of the household and relationship to the head for each of the other persons: for example 'wife', 'son', 'daughter-in-law', 'visitor', 'boarder', 'paying guest'.
- B6. Write 'single', 'married', 'widowed', or 'divorced' as appropriate. (If separated and not divorced write 'married')
- B7. Did the person have a job last week (the week ended 24th April 1971)? Tick box 1 if the person had a job even if it was only part time or if the person was temporarily away from work on holiday, sick, on strike, or laid off. If the person did not have a job, tick whichever of boxes 2, 3, 4 or 5 is appropriate; if box 5 is ticked state the reason, for example 'housewife', 'student', 'permanently sick'.
1. Yes - in a job at some time during the week
 2. No - seeking work or waiting to take up a job
 3. No - intending to seek work but sick
 4. No - wholly retired
 5. No - not seeking work for some other reason, namely
- (This question need not be answered for children under 15 years of age).
- B8. Will the person be a student attending full-time at an educational establishment during the term starting April/May 1971? (This question need not be answered by children under 15 years of age).
- B9. (a) If the person was born in England or Wales or Scotland or Northern Ireland, tick the appropriate box or (b) if the person was born in another country, write the name of the country (using the name by which it is known today) and the year in which the person first entered the United Kingdom.
- (a) Born in England, 01 Scotland, 02 Wales (incl. Monmouthshire), 03 Northern Ireland.
- (b) Born in(country) and entered U.K. in(year)

APPENDIX 1 (cont.)

- B10. Write the country of birth of (a) the person's father, (b) the person's mother. (This question should be answered even if the person's father or mother is no longer alive).
- B11. Was the person's usual address one year ago (on 25th April 1970) the same as that shown by the answer to question B4? Write 'Yes' or 'No'; if 'no', write also the usual address on 25th April 1970.
- B12. Was the person's usual address five years ago (on 25th April 1966) the same as that shown by the answer to that to question B4. Write 'Yes' or 'No'; if 'no', write also the usual address on 25th April 1966.
- B13. Has the person obtained any of the following?
1. GCE 'A' Level or Higher School Certificate
 2. Higher grade of Scottish Certificate of Education or of Scottish Leaving Certificate
 3. Ordinary National Certificate or Ordinary National Diploma
 4. None of these.
- (This question need not be answered for children under 15 or retired persons over 70).
- B14. Has the person obtained any of the following qualifications since reaching the age of 18?
- (a) HNC or HND, (b) Nursing qualifications, (c) Teaching qualifications, (d) Degrees, diplomas or any other educational qualifications, (e) Graduate or corporate membership of professional institutions, (f) Any other professional or vocational qualifications.
- (This question need not be answered for persons under 18 or retired persons over 70)
- Qualification
- Major subject or subjects
- Awarding institution
- Questions B15-B24 do not apply to children under 15 years of age. Answer questions B15-17 in respect of the main employment last week, or the most recent job if retired or out of work.
- B15. What was the name and business of the person's employer (if self-employed, the name and nature of the person's business)?
- B16. (a) What was the person's occupation; (b) Describe the actual work done in that occupation.
- B17. Was the person
1. An employee?
 2. Self-employed, employing others?
 3. Self-employed, without employees?

APPENDIX 1 (cont.)

- B18. If the person is an apprentice or trainee, write 'apprentice', 'articled clerk', 'articled pupil', 'student apprentice', 'graduate apprentice', 'management trainee', 'trainee technician', or 'trainee craftsman' as appropriate.
- B19. How many hours per week does the person usually work in this job? (Exclude overtime and meal breaks).
- B20. What is the full address of the person's place of work? (If the work is carried on mainly at home write 'at home').
- B21. What means of transport does the person normally use for the longest part, by distance, of the daily journey to work? (If the person walks to work, or works mainly at home, write 'none').
- B22. Was the person's occupation one year ago the same as last week? If so, write 'same'; if not, give details of the occupation one year ago.

Questions B23, 24 are to be answered for women aged under 60 who are married, widowed or divorced.

- B23. Enter the month and year of birth of each child born alive to her in marriage; include any who have since died.
- B24. (a) Write the month and year of marriage (the first marriage if married more than once)
 (b) If the marriage has ended (by the husband's death or by divorce) write the month and year when it ended.

PART C (not reproduced here) to be completed 'for any person who usually lives in this household but who is not present and for whom, therefore, no entry has been made in Part B'.

Appendix 2 (From C. Hakim (1978) OPCS Occasional Paper 11)

Number and types of areas for which 1971 Census data has been produced

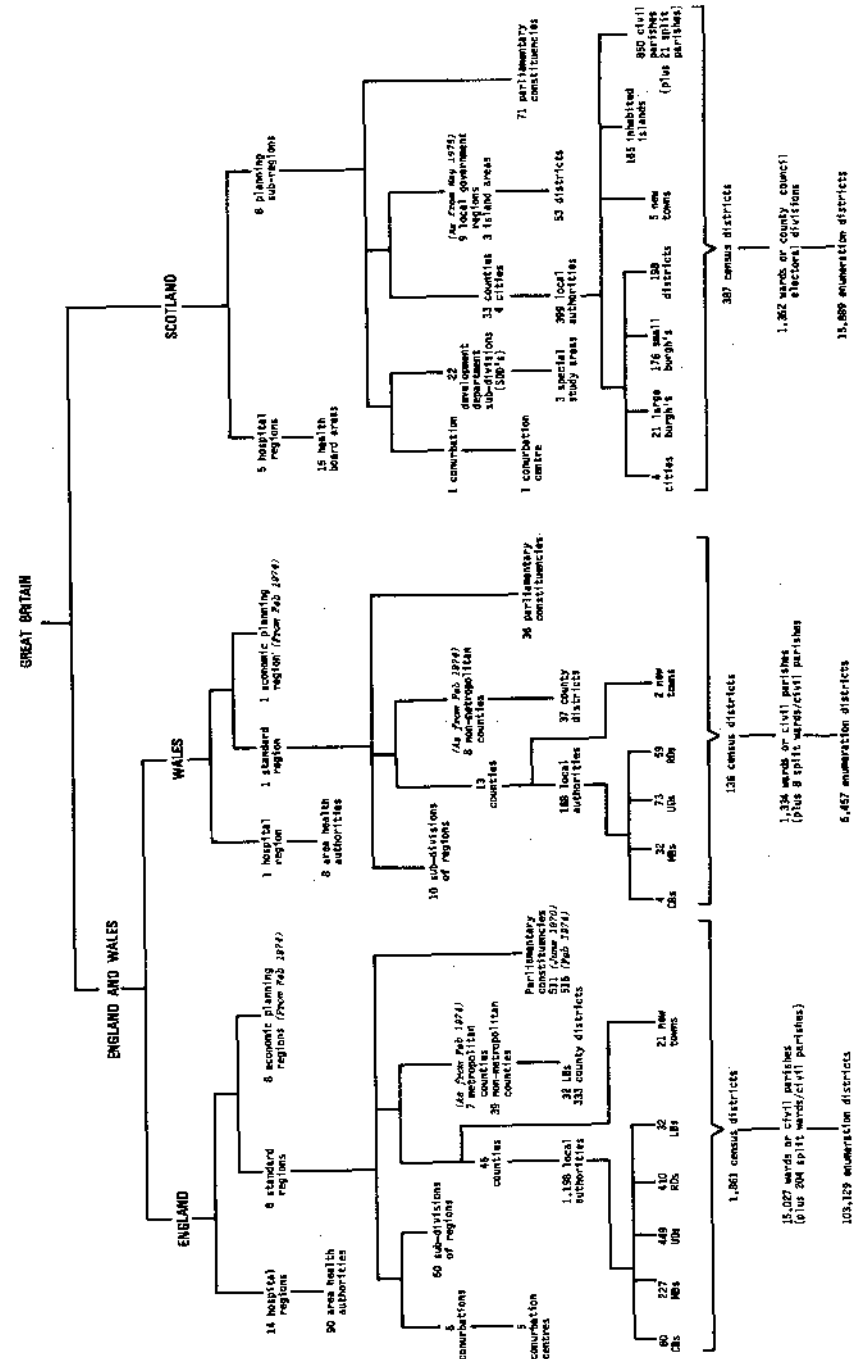

AREA IDENTIFICATION BOX		SMALL AREA STATISTICS (WARD LIBRARY)										100% POPULATION										SMALL AREA STATISTICS (WARD LIBRARY)										100% POPULATION																																																																																											
1		2					3					4					5					6					7					8					9																																																																																						
TOTAL POPULATION PRESENT		NOT IN PRIVATE HOUSEHOLDS					OTHER RESIDENTS					RESIDENTS WITH NEITHER PARENT BORN IN U.K.					BOTH PARENTS BORN IN U.S.A.					AGE					SEX					BIRTHPLACES OF PARENTS					RESIDENTS																																																																																						
Visitors etc. in U.A.		Males					Females					Males					Females					Males					Females					Males					Females																																																																																						
0	168 190	40	47	54	61	68	75	82	89	96	104	112	120	128	136	144	152	160	168	176	184	192	200	208	216	224	232	240	248	256	264	272	280	288	296	304	312	320	328	336	344	352	360	368	376	384	392	400	408	416	424	432	440	448	456	464	472	480	488	496	504	512	520	528	536	544	552	560	568	576	584	592	600	608	616	624	632	640	648	656	664	672	680	688	696	704	712	720	728	736	744	752	760	768	776	784	792	800	808	816	824	832	840	848	856	864	872	880	888	896	904	912	920	928	936	944	952	960	968	976	984	992	1000

OPCS GRO(S) Crown Copyright Reserved

AREA IDENTIFICATION BOX		SMALL AREA STATISTICS (WARD LIBRARY)										100% HOUSEHOLDS										SMALL AREA STATISTICS (WARD LIBRARY)										100% HOUSEHOLDS																																							
TOTAL POPULATION PRESENT		15					16					17					18					19					20					21					22																																		
Visitors etc. in U.A.		Present					Absent					Dwelling					No car					Dwelling					No car					Dwelling					No car																																		
Visitors etc. in U.A.		Males					Females					Males					Females					Males					Females					Males					Females																																		
0	168 190	32	35	37	34	35	36	37	38	39	40	41	42	43	44	45	46	47	48	49	50	51	52	53	54	55	56	57	58	59	60	61	62	63	64	65	66	67	68	69	70	71	72	73	74	75	76	77	78	79	80	81	82	83	84	85	86	87	88	89	90	91	92	93	94	95	96	97	98	99	100

OPCS GRO (S) Crown Copyright Reserved

AREA IDENTIFICATION BOX		SMALL AREA STATISTICS (WARD LIBRARY)										10% SAMPLE CENSUS 1971																			
22		ONE YEAR MIGRANTS WITHIN L.A.					ONE YEAR MIGRANTS INTO L.A.					ECONOMICALLY ACTIVE OR RETIRED					PERSONS IN EMPLOYMENT					PERSONS ACTIVE BUT NOT IN EMP.									
Age	S.W.D. Males	S.W.D. Females	Married Males	Married Females	S.W.D. Males	S.W.D. Females	Married Males	Married Females	S.W.D. Males	S.W.D. Females	Married Males	Married Females	Unmarried Males	Unmarried Females	Wages or salary	Unemployed	Retired	Wholesale & Retail Trade	Manufacturing	Construction	Transportation	Other	Why change in Y. L.A.A.	Wholesale & Retail Trade	Manufacturing	Construction	Transportation	Other	Net 6 (Urban) & Dist.		
1-5	32	39	46	53	60	67	74	81	182	199	186	204	237	254	274	286	305	322	339	354	368	383	397	411	425	439	453	467	481	495	
5-9	34	40	47	54	61	68	75	82	154	171	166	183	216	233	254	272	289	306	323	340	357	374	391	408	425	442	459	476	493	510	
9-14	35	36	42	49	56	63	70	77	135	152	147	164	197	214	235	256	277	298	319	340	361	382	403	424	445	466	487	508	529	550	571
14-19	36	43	50	57	64	71	78	85	136	153	148	165	198	215	236	257	278	299	320	341	362	383	404	425	446	467	488	509	530	551	572
19-24	37	44	51	58	65	72	79	86	137	154	149	166	200	217	238	259	280	301	322	343	364	385	406	427	448	469	490	511	532	553	574
24-29	38	45	52	59	66	73	80	87	138	155	150	167	201	218	239	260	281	302	323	344	365	386	407	428	449	470	491	512	533	554	575
29-34	39	46	53	60	67	74	81	88	139	156	151	168	202	219	240	261	282	303	324	345	366	387	408	429	450	471	492	513	534	555	576
34-39	40	47	54	61	68	75	82	89	140	157	152	169	203	220	241	262	283	304	325	346	367	388	409	430	451	472	493	514	535	556	577
39-44	41	48	55	62	69	76	83	90	141	158	153	170	204	221	242	263	284	305	326	347	368	389	410	431	452	473	494	515	536	557	578
44-49	42	49	56	63	70	77	84	91	142	159	154	171	205	222	243	264	285	306	327	348	369	390	411	432	453	474	495	516	537	558	579
49-54	43	50	57	64	71	78	85	92	143	160	155	172	206	223	244	265	286	307	328	349	370	391	412	433	454	475	496	517	538	559	580
54-59	44	51	58	65	72	79	86	93	144	161	156	173	207	224	245	266	287	308	329	350	371	392	413	434	455	476	497	518	539	560	581
59-64	45	52	59	66	73	80	87	94	145	162	157	174	208	225	246	267	288	309	330	351	372	393	414	435	456	477	498	519	540	561	582
64-69	46	53	60	67	74	81	88	95	146	163	158	175	209	226	247	268	289	310	331	352	373	394	415	436	457	478	499	520	541	562	583
69-74	47	54	61	68	75	82	89	96	147	164	159	176	210	227	248	269	290	311	332	353	374	395	416	437	458	479	500	521	542	563	584
74-79	48	55	62	69	76	83	90	97	148	165	160	177	211	228	249	270	291	312	333	354	375	396	417	438	459	480	501	522	543	564	585
79-84	49	56	63	70	77	84	91	98	149	166	161	178	212	229	250	271	292	313	334	355	376	397	418	439	460	481	502	523	544	565	586
84-89	50	57	64	71	78	85	92	99	150	167	162	179	213	230	251	272	293	314	335	356	377	398	419	440	461	482	503	524	545	566	587
89-94	51	58	65	72	79	86	93	100	151	168	163	180	214	231	252	273	294	315	336	357	378	399	420	441	462	483	504	525	546	567	588
94-99	52	59	66	73	80	87	94	101	152	169	164	181	215	232	253	274	295	316	337	358	379	400	421	442	463	484	505	526	547	568	589
99-104	53	60	67	74	81	88	95	102	153	170	165	182	216	233	254	275	296	317	338	359	380	401	422	443	464	485	506	527	548	569	590
Total	144	145	146	147	148	149	150	151	356	357	358	359	360	361	362	363	364	365	366	367	368	369	370	371	372	373	374	375	376	377	378
Age	FIVE YEAR MIGRANTS WITHIN L.A.					FIVE YEAR MIGRANTS INTO L.A.					ECONOMICALLY ACTIVE					PERSONS IN EMPLOYMENT					PERSONS ACTIVE BUT NOT IN EMP.										
5-9	96	102	108	114	120	126	132	138	144	150	156	162	168	174	180	186	192	198	204	210	216	222	228	234	240	246	252	258	264	270	276
9-14	97	103	109	115	121	127	133	139	145	151	157	163	169	175	181	187	193	199	205	211	217	223	229	235	241	247	253	259	265	271	277
14-19	98	104	110	116	122	128	134	140	146	152	158	164	170	176	182	188	194	200	206	212	218	224	230	236	242	248	254	260	266	272	278
19-24	99	105	111	117	123	129	135	141	147	153	159	165	171	177	183	189	195	201	207	213	219	225	231	237	243	249	255	261	267	273	279
24-29	100	106	112	118	124	130	136	142	148	154	160	166	172	178	184	190	196	202	208	214	220	226	232	238	244	250	256	262	268	274	280
29-34	101	107	113	119	125	131	137	143	149	155	161	167	173	179	185	191	197	203	209	215	221	227	233	239	245	251	257	263	269	275	281
34-39	102	108	114	120	126	132	138	144	150	156	162	168	174	180	186	192	198	204	210	216	222	228	234	240	246	252	258	264	270	276	282
39-44	103	109	115	121	127	133	139	145	151	157	163	169	175	181	187	193	199	205	211	217	223	229	235	241	247	253	259	265	271	277	283
44-49	104	110	116	122	128	134	140	146	152	158	164	170	176	182	188	194	200	206	212	218	224	230	236	242	248	254	260	266	272	278	284
49-54	105	111	117	123	129	135	141	147	153	159	165	171	177	183	189	195	201	207	213	219	225	231	237	243	249	255	261	267	273	279	285
54-59	106	112	118	124	130	136	142	148	154	160	166	172	178	184	190	196	202	208	214	220	226	232	238	244	250	256	262	268	274	280	286
59-64	107	113	119	125	131	137	143	149	155	161	167	173	179	185	191	197	203	209	215	221	227	233	239	245	251	257	263	269	275	281	287
64-69	108	114	120	126	132	138	144	150	156	162	168	174	180	186	192	198	204	210	216	222	228	234	240	246	252	258	264	270	276	282	288
69-74	109	115	121	127	133	139	145	151	157	163	169	175	181	187	193	199	205	211	217	223	229	235	241	247	253	259	265	271	277	283	289
74-79	110	116	122	128	134	140	146	152	158	164	170	176	182	188	194	200	206	212	218	224	230	236	242	248	254	260	266	272	278	284	290
79-84	111	117	123	129	135	141	147	153	159	165	171	177	183	189	195	201	207	213	219	225	231	237	243	249	255	261	267	273	279	285	291
84-89	112	118	124	130	136	142	148	154	160	166	172	178	184	190	196	202	208	214	220	226	232	238	244	250	256	262	268	274	280	286	292
89-94	113	119	125	131	137	143	149	155	161	167	173	179	185	191	197	203	209	215	221	227	233	239	245	251	257	263	269	275	281	287	293
94-99	114	120	126	132	13																										

APPENDIX 4 (cont.)

	1	2	3	4	5	6	7	8	9	10	11	12
12	*	*	*	*	*	*	*	*				*
13	*	*			*	*						*
14	*	*			*	*						*
15	*	*	*	*	*	*	*	*				*
16	*	*	*	*	*	*	*	*				*
17	*	*	*	*	*	*	*	*				*
18	*	*	*	*	*	*	*	*				*
19	*	*	*	*	*	*	*	*				*
20								*				
21	*	*	*	*	*	*	*	*				*
22	*	*	*	*	*	*	*	*				*

APPENDIX 4 (cont.)

	1	2	3	4	5	6	7	8	9	10	11	12
23							*	*				
24	*	*	*	*	*	*	*	*			*	*
25	*	*	*	*	*	*	*	*			*	*
26	*	*	*	*	*	*	*	*			*	*
27	*	*	*	*	*	*	*	*			*	*
28								*				
29	*	*	*	*	*	*	*	*			*	*
30	*	*	*	*	*	*	*	*			*	*
31	*											

Key to areas identified:

1. County, 2. Administrative County, 3. Aggregate of municipal Boroughs and Urban Districts, 4. Aggregate of Rural Districts, 5. County Boroughs, 6. Municipal Boroughs and Urban Districts with populations of 50 000 or more, 7. Municipal Boroughs and Urban Districts with populations of less than 50 000, 8. Rural Districts, 9. Wards (in urban areas), 10. Civil Parishes in Rural Districts, 11. Conurbation centres, 12. New Towns

APPENDIX 5 PUBLISHED VOLUMES OF THE 1971 CENSUS (1971 LAAS; volumes bound in blue covers)

TOPIC AND TITLE	NOTES	NO. of VOLs.	APPROXIMATE NO. of PAGES	% of TOTAL OUTPUT
A. PRELIMINARY DATA				
1. EW. Preliminary Report	1 vol. per Co. + 1 vol. NT. 1% sample	EM.1	60	4.6
2. SC. Preliminary Report		SC.1	20	
3. SC. Second Preliminary Report		SC.1	208	
4. EW. Advance Analysis		EW.60	1,000	
5. GB. Advance Analysis		GB.1	300	
6. GB. Summary Tables		GB.1	228	
B1. DEFINITIVE DATA PUBLISHED ON A COUNTY BASIS				
7. GB. County Reports	1 rpt per Co.; SC.1 vol; EW.3 vols., Pts. I, II, III; + 1 vol. SC.NT., 1 vol. EW.NT. SC.4 vols. by groups of planning regions; EW. 1 leaflet per Co.	GB.216	19,700	55.3
		(SC. 38)		
		(EW.178)		
		GB. 63		
8. GB. Economic Activity Tables		(SC. 4; EW. 59)	2,200	
B2. DEFINITIVE DATA PUBLISHED ON A "NATIONAL" BASIS				
(i) Birthplace and Usual Residence				
9. GB. Country of Birth Tables	GB. one volume 10% sample; Pt. I Housing & Household Composition; Pt. II Migration & Economic Activity EW. one volume SC. one volume	GB.1	228	2.9
10. EW. Country of Birth Supplementary Tables		EW.2	680	
		EW.1	88	
11. EW. Usual Residence Tables		SC.1	152	
12. SC. Usual Residence & Birthplace Tables				

APPENDIX 5 (cont.)

TOPIC AND TITLE	NOTES	NO. of VOLs.	APPROXIMATE NO. of PAGES	% of TOTAL OUTPUT
(ii) Housing				
13. GB. Housing Summary Tables	GB. one volume EW.3 vols; Pt. I Households; Pt. II Amenities; Pt. III Density of Occupation SC. one volume SC. one volume	GB.1	60	3.0
14. EW. Housing Tables		EW.3	770	
		SC.1	276	
		SC.1	70	
(iii) Households				
17. GB. Household Composition Summary Tables	10% sample; GB. 1 volume 10% sample; EW.3 vols, Pts. I, II, III SC. one volume	GB.1	118	3.1
18. EW. Household Composition Tables		EW.3	740	
19. SC. Household Composition Tables		SC.1	388	
(iv) Economic Activity (see also 8 above)				
20. GB. Economic Activity Tables	GB.6 vols; Pt. I (100%), Pts. II, III, IV, V (10%); Pt. VI sub-regional tables SC. 1 vol. (100%)	GB.6	1,500	4.1
21. SC. Economic Activity Tables		SC.1	126	
(v) Migration				
22. GB. Migration Tables	GB. 10% sample, Pts. I, II, IIIA, IIIB, IIIC, IV EW. 1 rpt per region; Pts. I, II, III (sometimes IIIA, IIIB, IIIC) SC. 10% sample; Pts. I, II, III, IV, V, VI SC. one volume	GB.6	980	16.9
23. EW. Migration Regional Reports		EW.30	4,600	
24. SC. Migration Tables		SC.6	980	
25. SC. Migration Tables (100%)		SC.1	154	

TOPIC AND TITLE	NOTES	NO. of VOLS.	APPROXIMATE NO. of PAGES	% of TOTAL OUTPUT
(vi) Workplace and Transport to Work				
26. EW. Workplace & Transport to Work Tables	EW. 10% sample, Pts. I, II	EW.2	680	2.0
27. SC. Workplace & Transport to Work Tables	SC. one volume	SC.1	120	
(vii) Summaries and Special Reports				
28. GB. Age, Marital Condition and General Tables	Population, econ. activities, households 100%; see also 30 above Two parts 3 vols.; Pt. I 100%; Pts. II, III 10% EW. one volume	GB.1	94	8.1
29. GB. Non-private Households		GB.1	220	
30. GB. Qualified Manpower Tables		GB.1	138	
31. GB. Persons of Pensionable Age		GB.1	340	
32. SC. Population Tables		SC.1	228	
33. SC. Scottish Population Summary		SC.1	20	
34. SC. Gaelic Report		SC.1	48	
35. SC. Qualified Manpower Tables		SC.1	30	
36. SC. Fertility Tables		SC.2	500	
37. EW. Fertility Tables		EW.3	1,000	
38. EW. Availability of Cars	EW.1	92		
39. EW. New Towns: Economic Activity, Workplace and Transport to Work			3,207	
40. WA. Summary Tables	EWNT.1	108	180	100.0
41. WA. Report on the Welsh Language in Wales	WA.1	209		
Totals		431	39,633	

Abbreviations

Co. = County; EW. = England and Wales; GB. = Great Britain; NT. = New Towns; Pt. = Part; rpt = report; SC. = Scotland; vol. = volume; WA. = Wales.

APPENDIX 6.

THE GEOGRAPHY OF THE 1971 CENSUS

Attention has already been drawn (Section IV(ii) above) to the large number and great diversity of the territorial units for which census data are published, and the full range of census areas is displayed in the diagram at Appendix 2. It is clearly impossible, within the confines of this booklet, to produce a complete index or listing of all the areas involved, but it was considered desirable to include a series of maps to show some of the patterns of areal units referred to in the text.

Reference has been made to the reorganisation of local government boundaries which occurred in 1974 in England and Wales and in 1975 in Scotland, and the resultant publication of two sets of census volumes for pre- and post- 1974/75 LAAs respectively. This aspect is covered in Maps 1 and 2, which show changes at the county level. In England, many of the traditional counties remained unchanged or suffered only relatively minor boundary adjustments. There were, however, a number of more radical alterations. In several instances, old counties were amalgamated to form new ones: Herefordshire and Worcestershire, for example, became a single county, as did the former counties of Cambridgeshire and Isle of Ely and Huntingdon and Peterborough (themselves both the product of earlier amalgamations); the three 'Parts' of Lincolnshire were combined, so were East Suffolk and West Suffolk; the new County of Cumbria was created from Cumberland, Westmorland, the Furness district of Lancashire and a small section (Sedburgh R.D.) of Yorkshire, West Riding. Completely new counties included Avon, created from parts of Gloucestershire and Somerset, and Cleveland (formerly part of Yorkshire, North Riding) but the most striking innovation in England was the establishment of six Metropolitan Counties to cover the most heavily urbanised and densely populated sections of the country, namely Tyne and Wear, West Yorkshire, South Yorkshire, Greater Manchester, Merseyside and West Midlands (A seventh Metropolitan County - Greater London - was already in existence in 1971.)

whereas in England the total number of counties (46) remained the same, more drastic boundary revision occurred in Wales, where 13 old counties were re-organised into eight new ones, and in Scotland, where the 33 traditional counties were replaced by nine administrative Regions and three Island Areas. Thus, for Great Britain as a whole, the number of units at this level was cut from 92 to 66.

One objective of this reorganisation was to reduce the number of units with very small populations. Of the 1971 counties, 16 in Scotland and three in Wales had fewer than 50 000 inhabitants; the problem was less severe in England, where the smallest counties were Rutland (27 000), Westmorland (99 000) and the Isle of Wight (109 000). Even so there is still a wide range of population sizes in the post 1974/75 divisions; 12 have populations in excess of one million, 23 have 500 000-1 000 000, 26 have 100 000-500 000, and there are five (Borders, the three Island Areas and Powys) with less than 100 000 each.

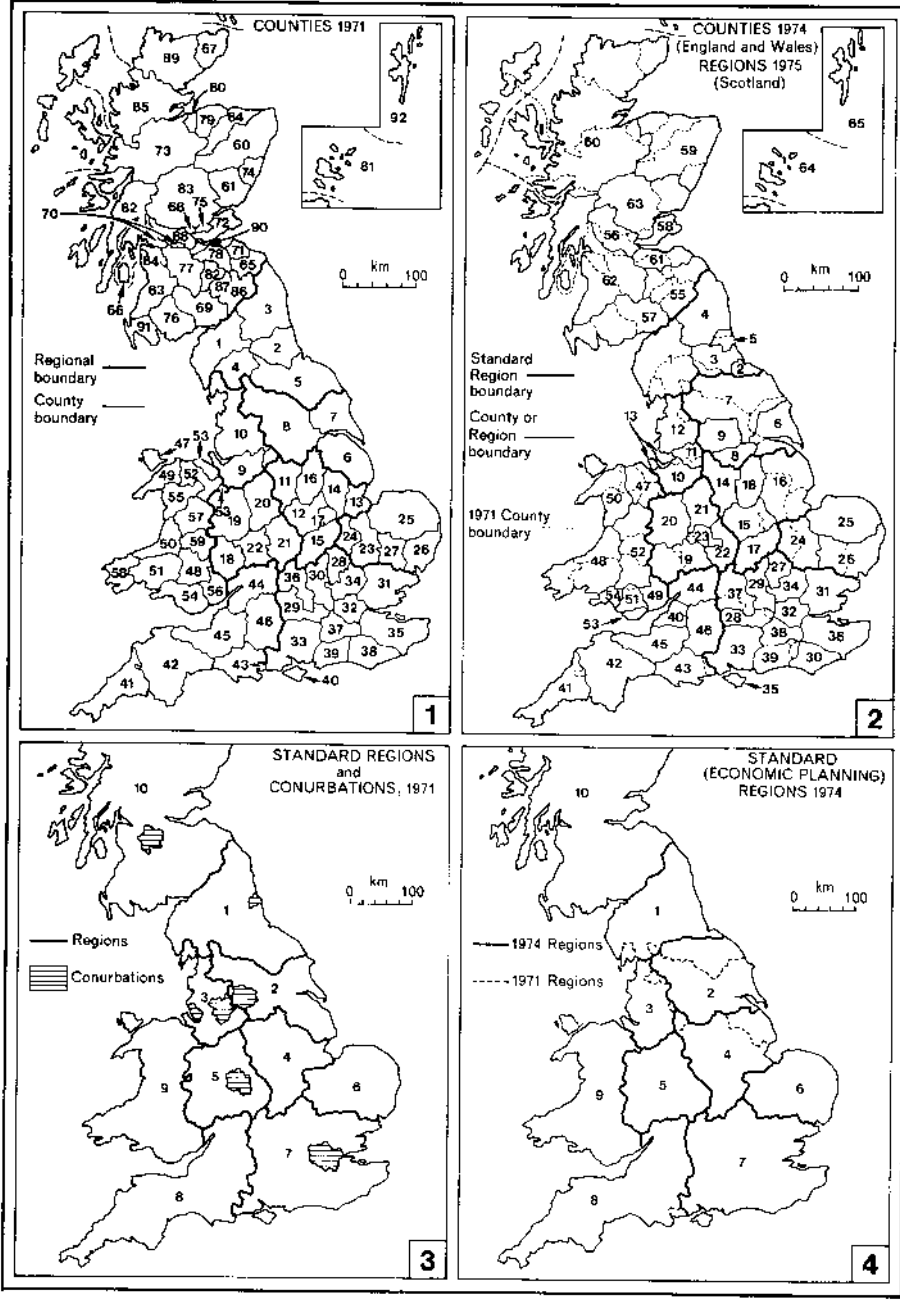

KEY TO MAPS 1-4: STANDARD REGIONS OF GREAT BRITAIN, OLD and NEW COUNTIES of ENGLAND and WALES, FORMER COUNTIES and NEW ADMINISTRATIVE REGIONS OF SCOTLAND, WITH THEIR 1971 POPULATIONS (in thousands)

1971 (Maps 1 and 3)

1. NORTH	3,292	3,386
1. Cumberland	292	807
2. Durham	1,408	771
3. Northumberland	795	106
4. Westmorland	73	232
5. Yorkshire, North Riding (Lyneside conurbation (Region remainder	724 804) 2,488)	468 975 27
2. YORKSHIRE and HUMBERSIDE	4,795	5,105
6. Lincolnshire, Parts of Lindsey	471	138
7. Yorkshire, East Riding	543	337
8. Yorkshire, West Riding (West Yorkshire conurbation (Region remainder	3,781 1,726) 3,069)	1,857 2,080 693
3. NORTH WEST	6,726	2,369)
9. Cheshire	1,543	2,736)
11. Derbyshire (part of)	77	1,666
10. Lancashire (Merseyside conurbation (South East Lancashire conurbation (Region remainder	5,106 1,262) 2,387) 3,077)	303 202 616 381 164

7. SOUTH EAST		17,133	9. WALES		2,724
28.	Bedfordshire	463	47.	Anglesey	60
29.	Berkshire	633	48.	Breconshire	53
30.	Buckinghamshire	586	49.	Caernarvonshire	123
43.	Dorset (part of)	107	50.	Cardiganshire	55
31.	Essex	1,354	51.	Carmarthenshire	162
32.	Greater London	7,379	52.	Denbighshire	185
33.	Hampshire	1,562	53.	Flintshire	175
34.	Hertfordshire	922	54.	Glamorgan	1,255
35.	Kent	1,396	55.	Merionethshire	35
36.	Oxfordshire	381	56.	Monmouthshire	461
37.	Surrey	1,000	57.	Montgomeryshire	43
38.	Sussex, East	750	58.	Pembrokeshire	97
39.	Sussex, West	491	59.	Radnorshire	18
40.	Wight, Isle of	109	<u>10. SCOTLAND</u>		
(Greater London conurbation		7,379)	60.	Aberdeen	320
(Region remainder		9,754)	61.	Angus	279
<u>8. SOUTH WEST</u>		3,767	62.	Argyll	60
41.	Cornwall	380	63.	Ayr	361
42.	Devon	896	64.	Banff	44
43.	Dorset (part of)	254	65.	Berwick	21
44.	Gloucestershire	1,069	66.	Bute	13
45.	Somerset	682	67.	Caithness	28
46.	Wiltshire	486	68.	Clackmannan	46
			69.	Dumfries	88

46

70.	Dunbarton	238	83.	Perth	127
71.	East Lothian	56	84.	Renfrew	362
72.	Fife	327	85.	Ross and Cromarty	58
73.	Inverness	90	86.	Roxburgh	42
74.	Kincardine	26	87.	Seikirk	21
75.	Kinross	6	88.	Stirling	209
76.	Kirkcudbright	27	89.	Sutherland	13
77.	Lanark	1,524	90.	West Lothian	108
78.	Midlothian	596	91.	Wigtown	27
79.	Moray	51	92.	Zetland	17
80.	Nairn	11	(Central Clydeside conurbation		
81.	Orkney	17	(Region remainder		
82.	Peebles	14	1,731)		
			3,497)		

47

1974/75 (Maps 2 and 4)		3. NORTH WEST		6,595	
1.	<u>NORTH</u>	3,142	10.	Cheshire	868
1.	Cumbria	476	11.	Greater Manchester (Metropolitan County)	2,729
2.	Cleveland	567	12.	Lancashire	1,341
3.	Durham	608	13.	Merseyside (Metropolitan County)	1,657
4.	Northumberland	280	<u>4. EAST MIDLANDS</u>		
5.	Tyne and Wear (Metropolitan County)	1,211	14.	Derbyshire	886
<u>2. YORKSHIRE and HUMBERSIDE</u>		4,857	15.	Leicestershire	799
6.	Humberside	838	16.	Lincolnshire	503
7.	North Yorkshire	629	17.	Northamptonshire	468
8.	South Yorkshire (Metropolitan County)	1,322	18.	Nottighamshire	973
9.	West Yorkshire (Metropolitan County)	2,068			

5. WEST MIDLANDS	4,911
19. Hereford and Worcester	362
20. Salop	337
21. Staffordshire	963
22. Warwickshire	456
23. West Midlands (Metropolitan County)	2,793
6. EAST ANGLIA	1,666
24. Cambridgeshire	505
25. Norfolk	624
26. Suffolk	537
7. SOUTH EAST	16,834
27. Bedfordshire	463
28. Berkshire	620
29. Buckinghamshire	476
30. East Sussex	650
31. Essex	1,354
32. Greater London (Metropolitan County)	7,379
33. Hampshire	1,370
34. Hertfordshire	922
35. Isle of Wight	109
36. Kent	1,396
37. Oxfordshire	504
38. Surrey	981
39. West Sussex	610

48

8. SOUTH WEST	4,064
40. Avon	902
41. Cornwall	377
42. Devon	896
43. Dorset	553
44. Gloucestershire	463
45. Somerset	387
46. Wiltshire	486
9. WALES	2,724
47. Clwyd	358
48. Dyfed	314
49. Gwent	440
50. Gwynedd	220
51. Mid Glamorgan	531
52. Powys	99
53. South Glamorgan	390
54. West Glamorgan	372

10. SCOTLAND	5,228
55. Borders	99
56. Central	263
57. Dumfries and Galloway	144
58. Fife	328
59. Grampian	437
60. Highland	175

61. Lothian	742
62. Strathclyde	2,578
63. Tayside	397
64. Orkney (Island Area)	17
65. Shetland (Island Area)	18
66. Western Isles (Island Area)	31

49

Reorganisation of local government was accompanied by modifications to the Standard (Economic Planning) Regions as shown in Maps 3 and 4. Scotland and Wales remained unchanged, as did East Anglia; there were relatively minor adjustments to the boundaries of the West Midlands, South East and South West but the North, Yorkshire and Humberside, the North West and the East Midlands were radically changed.

The names and 1971 populations of Standard Regions and county level divisions are given in the accompanying 'key to Maps 1-4'.

The reorganisation of local government below the county level was even more drastic than that of the counties themselves. Prior to 1974/75, and thus at the time of the 1971 census, Great Britain was divided into 1,765 Local Authority Areas of various types. England had 1,198 LAAs (32 London Boroughs, 80 County Boroughs, 227 Municipal Boroughs, 449 Urban District and 410 Rural Districts); Wales had 168 (4 C.B.s, 32 M.B.s, 73 U.D.s and 59 R.D. ^); in Scotland there were 399 (4 Cities, 21 Large Burghs, 176 Small Burghs and 198 Districts of County). The populations of these units ranged from nearly 900 000 in the City of Glasgow to less the 1000 in several of the Small Burghs and Districts of County. The 1974/75 reorganisation replaced this complex system by a simple division of counties (regions in Scotland) into Districts (termed Metropolitan Districts within the Metropolitan Counties of England, except in the case of London, where the existing London Boroughs were retained). There are 458 of these new units; 365 in England (32 London Boroughs, 36 Metropolitan Districts, 297 Districts), 37 in Wales and 56 in Scotland (including the three Island Areas). The effects of these changes in selected areas of Scotland, Wales, South Eastern and Northern England are shown by Maps 5-8, each of which covers an area of 80 x 80 km.

Map 5 shows the particularly complex situation in west-central Scotland in 1971, where the mapped area was divided among eight counties and included one City (Glasgow), some 40 Burghs and the whole or part of 35 Districts of County. Following the 1975 reorganisation, practically the whole area lies within Strathclyde and is divided into 25 Districts.

Map 6 portrays a somewhat similar situation in the South Wales coalfield, where four County Boroughs, 38 M.B.s or U.D.s and 20 R.D.s, have been replaced by some 20 new Districts; the number of counties has increased as a result of the division of Glamorgan into three new counties.

Map 7 covers an area between London and the Channel coast. Outside Greater London (which remained unchanged in 1974) 64 1971 LAAs were reduced to about 30 in 1974. County boundaries remained the same apart from the transfer of one District from west to East Sussex and a small modification of the Surrey-Sussex border.

Map 8 shows North East England from the Tyne to the Tees. Two new counties - Tyne-wear and Cleveland - were created in 1974 and there were modifications to the boundaries of Durham, Northumberland and the North Riding. Within the revised counties, the 60 LAAs of 1971 were replaced by 24 new Districts.

While Maps 1-8 show territorial units for which a wide range of data are tabulated in the various published census volumes, Map 9 displays wards (in urban areas) and Civil Parishes (in Rural Districts), for which only the

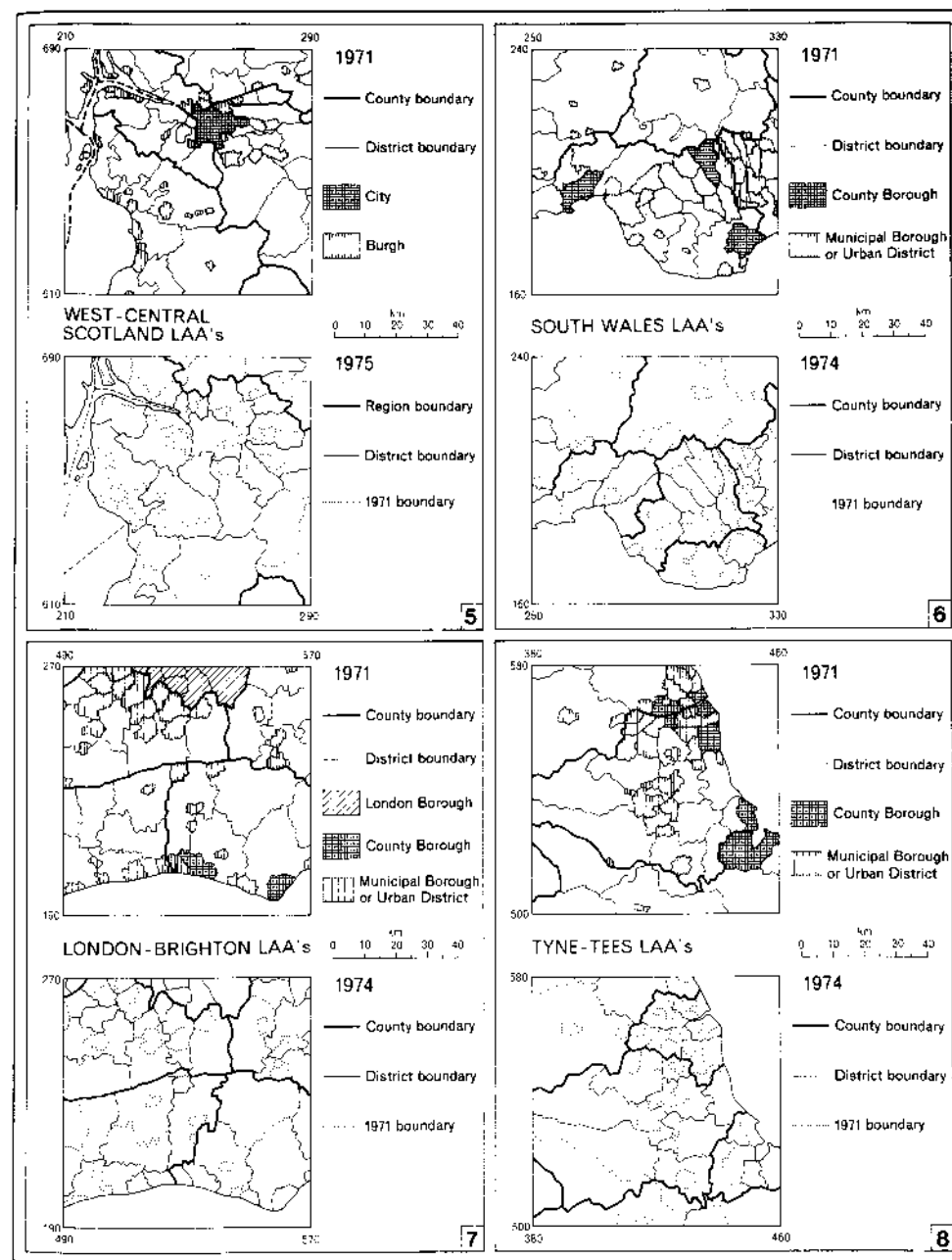

numbers of people and households are given (though more details can be obtained on request from OPCS). Map 9 covers County Durham within its 1971 boundaries and shows the boundaries of its 36 LAAs as well as their subdivision into wards and Civil Parishes. These units, the smallest for which any data appear in the published volumes, numbered 377; there were 220 wards (including two small U.D.s not subdivided) and 157 Civil Parishes, giving an average area of 680 ha and an average population of 3,740. As the map indicates, there is a very large size range: Stanhope C.P. in the extreme west, for example, covers 25 589 ha, while there are several small urban wards of less than 50 ha. There is also a great range of population sizes, generally inverse to that of area, from less than 100 in several rural parishes to over 10 000 in a dozen urban wards, and population density varies from above 150 to below 0.1 per ha.

Finally, Map 10 gives an example of the pattern of Enumeration Districts. The area shown here is the Newcastle upon Tyne Metropolitan District (part of Tyne and Wear Metropolitan County) as established in 1974, embracing the old Newcastle County Borough, Gosforth and Newburn Urban Districts and five parishes from the old Castle Ward Rural District. For the 1971 census this was divided into 12 Census Areas and nearly 600 E.Ds.

The Metropolitan District includes not only some of the most densely populated urban areas in the country, but also, in the north and west, a good deal of thinly settled rural territory, and this is reflected in the great size range of the Enumeration Districts. Very small, often rectangular E.Ds denote the presence of high density grid-iron terraced housing as in Heaton (Grid.Ref. 275 657), Byker (273 645) or Elswick (222 638). Newer residential areas with curved street patterns are also visible, for example in High Heaton (268 668) and Blakelaw (212 665). The convoluted and interlocking shapes of many E.Ds result from attempts to allocate near-equal numbers of persons and households to each unit. Large E.Ds occur not only in peripheral rural areas but also in the central part of the city and along the Tyne where commercial and industrial functions predominate and population densities are low. The very large E.D. centred at G.R. 240 663 includes the Town Moor open space and a small residential area attached to it to give this E.D. the appropriate population size.

For the Metropolitan District as a whole, the average size of an Enumeration District is about 20 ha and the average population around 500 compared with averages of 138 ha and 443 people for England and Wales as a whole. Map 10 also shows the layout of 1 km grid squares, which are discussed in the main body of the text as an areal framework alternative to that provided by Enumeration Districts. In this instance, the average E.D. is much smaller than a 1-km square and 100 metre grid squares would have to be used to provide a picture more detailed than that provided by E.D. data. In the large E.Ds of the north and west, however, 1-km squares give a finer resolution than E.Ds.

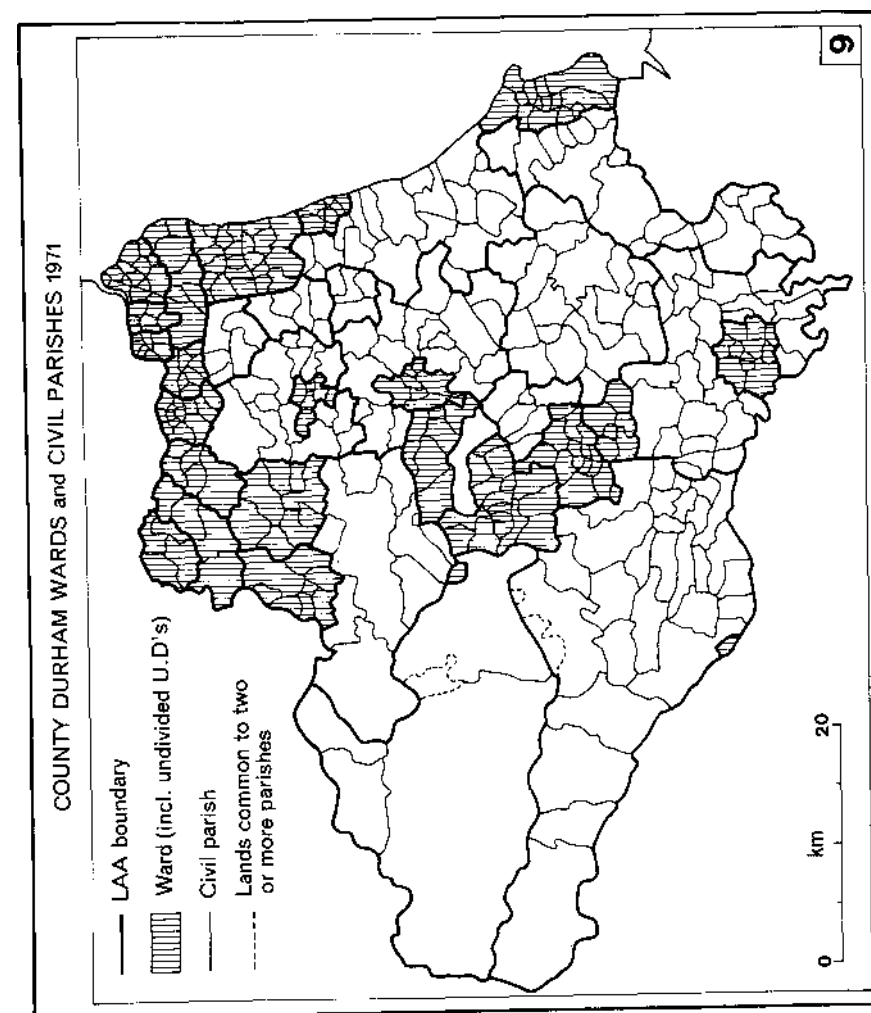

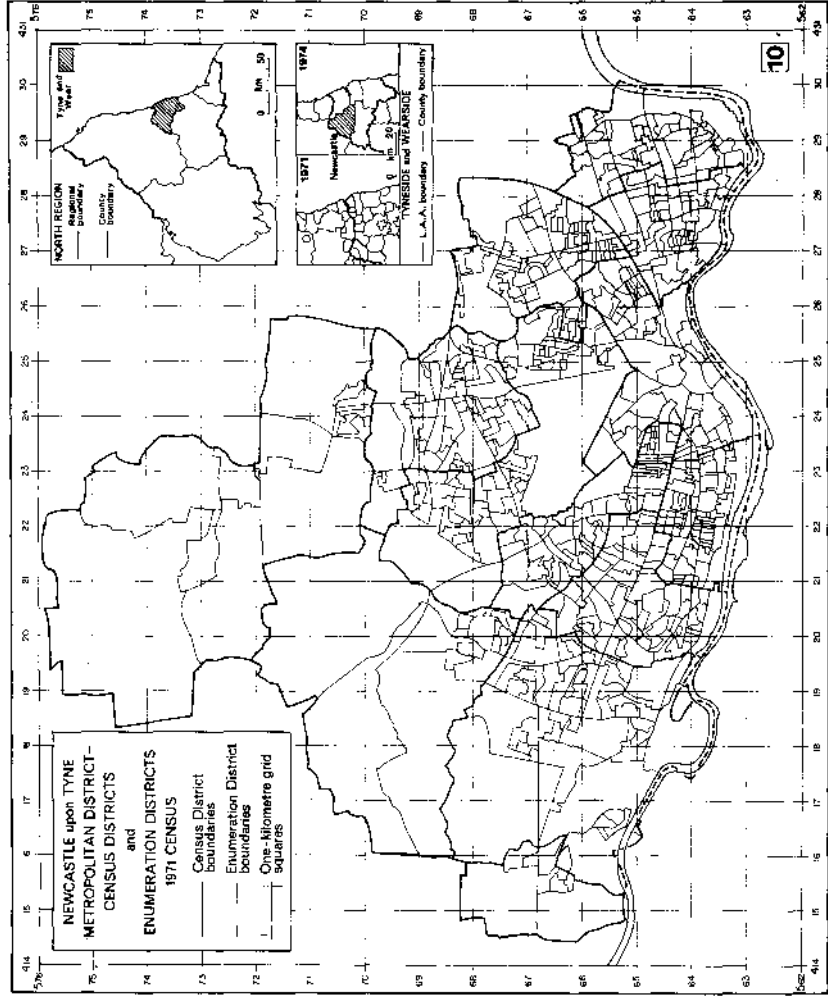

25. Directional statistics - G.L. Gaile & J.E. Burt
26. Potential models in human geography - D.C. Rich
27. Causal modelling: the Simon-Blalock approach - D.G. Pringle
28. Statistical forecasting - R.J. Bennett
29. The British Census - J.C. Dewdney
30. The analysis of variance - J. Silk
31. Information statistics in geography - R.W. Thomas
32. Centographic measures in geography - A. Kellerman

This series, Concepts and Techniques in Modern Geography, is produced by the Study Group in Quantitative Methods, of the Institute of British Geographers.

For details of membership of the Study Group, write to the Institute of British Geographers, 1 Kensington Gore, London, S.W.7.

The series is published by Geo Abstracts, University of East Anglia, Norwich, NR4 7TJ, to whom all other enquiries should be addressed.