

## Causal and Simulation Modelling Using System Dynamics

---



---

Dr. Ian Moffatt

Senior Research Fellow  
North Australia Research Unit  
PO Box 41321, Casuarina NT 0811 Australia

## Listing of Catmogs in print

---

CATMOGS (Concepts and Techniques in Modern Geography) are edited by the Quantitative Methods Study Group of the Institute of British Geographers. These guides are both for the teacher, yet cheap enough for students as the basis of classwork. Each CATMOG is written by an author currently working with the technique or concept he describes.

For details of membership of the Study Group, write to the Institute of British Geographers

1:	Collins, Introduction to Markov chain analysis.	3.00
2:	Taylor, Distance decay in spatial interactions.	3.00
3:	Clark, Understanding canonical correlation analysis.	3.00
4:	Openshaw, Some theoretical and applied aspects of spatial interaction shopping models. (fiche only)	3.00
5:	Unwin, An introduction to trend surface analysis.	3.00
6:	Johnston, Classification in geography.	3.00
7:	Goddard & Kirby, An introduction to factor analysis.	3.00
8:	Daultrey, Principal components analysis.	3.50
9:	Davidson, Causal inferences from dichotomous variables.	3.00
10:	Wrigley, Introduction to the use of logit models in geography.	3.00
11:	Hay, Linear programming: elementary geographical applications of the transportation problem.	3.00
12:	Thomas, An introduction to quadrat analysis (2nd ed.).	3.00
13:	Thrift, An introduction to time geography.	3.00
14:	Tinkler, An introduction to graph theoretical methods in geography.	3.50
15:	Ferguson, Linear regression in geography.	3.00
16:	Wrigley, Probability surface mapping. An introduction with examples and FORTRAN programs. (fiche only)	3.00
17:	Dixon & Leach, Sampling methods for geographical research.	3.00
18:	Dixon & Leach, Questionnaires and interviews in geographical research.	3.50
19:	Gardiner & Gardiner, Analysis of frequency distribution. (fiche only)	3.00
20:	Silk, Analysis of covariance and comparison of regression lines.	3.00
21:	Todd, An introduction to the use of simultaneous-equation regression analysis in geography.	3.00
22:	Pong-wai Lai, Transfer function modelling: relationship between time series variables.	3.00
23:	Richards, Stochastic processes in one dimensional series: an introduction.	3.50
24:	Killen, Linear programming: the Simplex method with geo-graphical applications.	3.00
25:	Gaile & Burt, Directional statistics.	3.00
26:	Rich, Potential models in human geography	3.00
27:	Pringle, Causal modelling: the Simon-Blalock approach.	3.00
28:	Bennett, Statistical forecasting.	3.00
29:	Dewdney, The British census.	3.50

*(continued inside back cover)*

## CAUSAL AND SIMULATION MODELLING USING SYSTEM DYNAMICS

**Dr Ian Moffatt**

Senior Research Fellow  
North Australia Research Unit  
PO Box 41321, Casuarina NT 0811 Australia

# CONTENTS

## LIST OF FIGURES

LIST OF FIGURES	3	1	A river basin water system	8	
LIST OF TABLES	4	2	Seven phases in system dynamics model building	10	
ACKNOWLEDGEMENTS	6	3	Types of causality	13	
CHAPTER I DYNAMIC MODELS AND ENVIRONMENTAL SYSTEMS	7	4	The trajectory of a state variable to a state of dynamic equilibrium	14	
CHAPTER II CAUSAL MODELS AND QUALITATIVE SYSTEM DYNAMICS	9	5	Causal diagrams illustrating positive and negative feedback loops	16	
i	The use of a systems approach in environmental science	9	6a	A population dynamics model	17
(ii)	Causality and causal models	12	6b	A four age cohort demographic model	17
iii		14	7	Two trajectories of population growth	18
CHAPTER III COMPUTER SIMULATION AND QUANTITATIVE SYSTEM DYNAMICS	18	8	A simple demographic digraph	19	
(ii)	From digraphs to DYNAMO flowcharts	18	9	A DYNAMO flowchart of population dynamics	19
iii	Writing a DYNAMO program	20	10	Time subscripts J, JK, KL in DYNAMO	21
(iv)	Logistic growth model	23	11	A digraph of a new model of population dynamics	24
(v)	Difference equations and system dynamics	26	12	A DYNAMO flowchart of the new model of population dynamics	24
CHAPTER IV MODEL EVALUATION AND SYSTEM DYNAMICS	30	13	Graphing the population increase, A POP, during a time interval, A t	27	
Model evaluation	30	14	Actual and predicted temperature change for a hypothetical system	33	
The use of statistical methods	34	15a	A digraph for simulating algal growth	36	
Eutrophication: an example of basic scientific research	35	15b	A DYNAMO model of algal growth	37	
(iv)	World dynamics: an example of policy orientated research	39	16	Hypothesised reference modes of the 'limits to growth' global models	39
CHAPTER V CONCLUSION: THE LIMITS TO SYSTEM DYNAMICS	43	17	The basic mechanisms that underlie the reference mode of Figure 16b	40	
REFERENCES	47	18a	World 3 reference run	41	
		18b	World 3: equilibrium through adaptive policies	42	

## LIST OF TABLES

1	An elementary DYNAMO program	23
2	Results of the exponential and logistic population growth model for England and Wales, 1901-2001	28
3	Tests for evaluating system dynamics models	30
4	A DYNAMO program for Nitrogen Algal Model	38
5	Results of the Nitrogen Algal Model	39

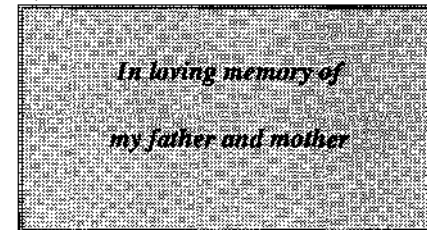

## ACKNOWLEDGMENTS

I would like to thank the following people for helping to produce this manuscript. Ken Docherty for drawing the figures; Elizabeth Urqhart and Janet Sincock for wordprocessing my early drafts of the text; Martyn Senior for his helpful editorial comments. Richard Huggett and Dennis Meadows and their publishers, Oxford University Press and Wright Allen for giving their permission to reproduce figures from their books. Finally, I would like to thank my former students at the University of Stirling for their constructive comments on several courses on modelling environmental systems from which this book emerged.

## I DYNAMIC MODELS AND ENVIRONMENTAL SYSTEMS

Geographers and environmental scientists have a common philosophical goal namely to understand 'the vast interacting system comprising all humanity with its natural environment on the surface of the earth' (Ackerman, 1963, 453). In an attempt to understand such a complex system or set of subsystems it is essential that we develop appropriate techniques to aid our substantive investigations. There are, of course, a whole host of techniques available to geographers and environmental scientists but only a few pedagogic studies have examined the role of dynamic model building (Wilson, 1981a, 1981b; Thomas and Huggett, 1980). The system dynamics approach offers another approach to building dynamic simulation models of environmental systems.

Any dynamic model may be defined as a simplification of a real world system which changes through time and space. This apparently straightforward definition of dynamic models hides a bewildering array of dynamic behaviour found in such models (May, 1976). This dynamic behaviour has been uncovered by using various techniques such as dynamic entropy maximizing models (Wilson, 1981a, 1981b), dynamic systems theory (Clarice and Wilson, 1981), statistical forecasting (Bennett, 1980) and system dynamics (Forrester, 1961). It is important to stress, however, that these various forms of dynamic behaviour are observed in the real world rather than being an artefact of the methods used to investigate the 'real' world. Furthermore, it is important to note that system dynamics modelling is not a statistical technique per se but one approach to causal and simulation modelling which geographers and environmental scientists may find useful in their substantive work.

There are numerous texts which describe examples of environmental systems (Bennett and Chorley, 1978; Wilson, 1981b; Jorgensen, 1986; Jeffers, 1978, 1987). Fundamentally, any environmental system can be conceptualized as a series of inputs, outputs and most important a series of inter-dependencies between the elements which make up the system. These interactions can be illustrated by the flows of water in a catchment forming a river basin water system (Figure 1).

This system consists of stores of water which are interconnected by a series of causal processes. Generally, precipitation is the major exogenous input to the system. The water from this source enters the soil directly by infiltration, is temporarily stored on the soil surface as surface storage such as lochs, or is intercepted by and temporarily stored on vegetated surfaces. Water stored in or on the soil may flow down the valley side slopes by overland flow, throughflow or pipe-flow to feed the rivers in the catchment. Alternatively, the sub-surface water may percolate downwards to recharge the ground water storage. The latter may be influenced by deep-storage or the water may rise by capillary action and pass in to the soil storage. Often in environmental systems human activity is responsible for extracting resources such as water for agricultural, industrial and domestic uses. Furthermore, water used by us is often returned to the system in a polluted form. In most stores evaporation or evapotranspiration feeds moisture back to the surrounding atmosphere.

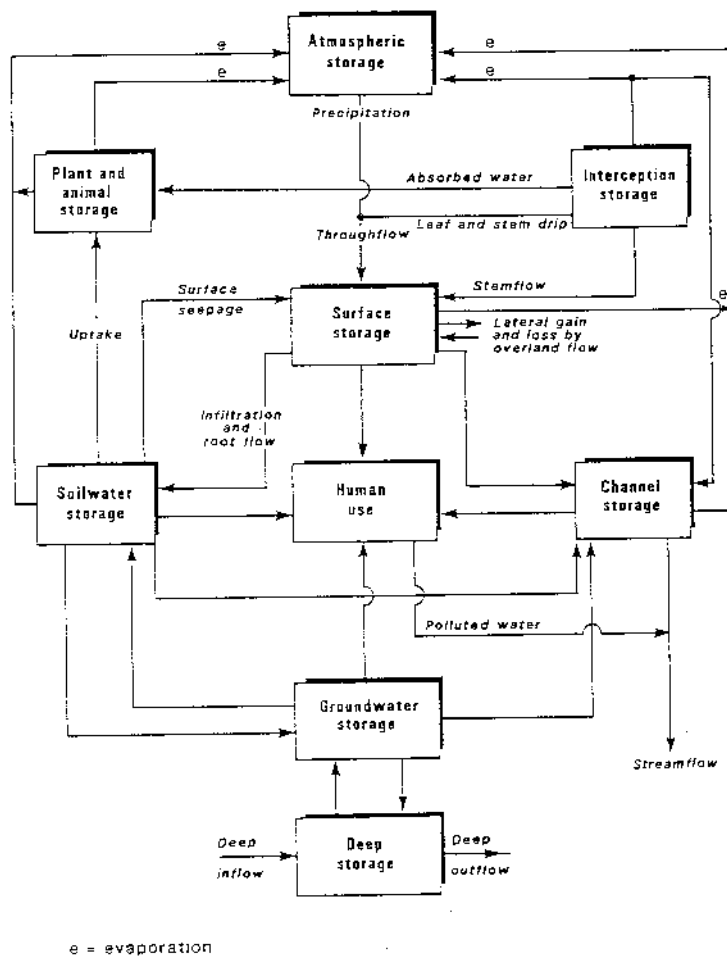

Figure 1 A river basin water system (after Huggett, 1980)

Several general points emerge from this simple illustration of an environmental system. First, any description of a real system attempts to bring together various aspects of knowledge from systemic disciplines. As Wilson (1981b, 19) notes, "an important advantage of a systems approach is the natural tendency to avoid disciplinary myopia". Next, as a corollary, in any systems approach it is almost inevitable to omit some apparently less important aspect of the real system under investigation so that the model of the system is a simplified and intelligible version of complex real phenomena. Third, the major feature of the flows between these various stores are controlled by processes. These processes may be natural, man-made or a combination of both. Yet, it is the correct specification of these processes which gives a causal model of a system its dynamic behaviour. Failure to specify these causal processes exactly can result in a misleading simulation of the system under investigation. Fourth, it is obvious from the above informal stages of the argument that causal processes underlying an environmental system are complex and much basic scientific research is required to comprehend the ways in which these individual processes interact to give a system its dynamism. Finally, attempts to plan and manage such systems should not be too simplistic and fail to take into account the complex behaviour which results from the interactions of two or more elements in systems operating in a holistic manner.

From the above brief description of a river basin water system it is clear that any model of an environmental system can be used as either a contribution to basic scientific research or as an aid to policy orientated decision making. The objective of the former is to increase our explanation of a system whilst policy orientated research attempts to monitor or forecast the likely impact of a particular policy on the real world system. Increasingly environmental systems are the focus of both scientific research and policy orientated studies.

Although environmental systems may be very complex it is important that models of these systems should be kept as simple as possible to reveal the basic structure of the causal processes underlying the behaviour of the system. The rest of this CATMOU attempts to explain the system dynamics approach to causal modelling. System dynamics, like other system analytical approaches, has been used in both scientific research and policy orientated work. No knowledge of model building or computer programming is assumed. The only pre-requisite is a knowledge of elementary mathematical skills.

## II CAUSAL MODELS AND QUALITATIVE SYSTEM DYNAMICS

(i) The use of a systems approach in environmental science.

Systems dynamics, as the name implies, is concerned with the dynamic behaviour of real world systems. More formally the methodology of system dynamics can be defined as

*A rigorous method for problem identification, system description, qualitative modelling and analysis of change in*

*complex systems; which facilitates and can lead to quantitative modelling and dynamic analysis for the design of system structure and control' (Wolstenholme, 1985,1052).*

Like other methods which use a systems approach to substantive problems system dynamics emphasises the connection and interactions among the various elements of a system which, in some sense, constitute a whole. By its very nature system dynamics, like other system based methodologies uses both analytical techniques to examine the interactions between elements of a system whilst it also attempts some form of functional synthesis to show how the system changes and evolves. When using a system dynamics approach to tackle complex environmental problems it is obvious that the inputs of many traditional sciences and other academic studies may be incorporated in order to give a partial explanation of the problem.

There are seven stages in the use of system dynamics in studying and solving problems. First it is essential to define the problem as clearly as possible. This is an essential and difficult task. Generally, a problem can be defined as an unsatisfied need to change an unusual observation to an expected observation. A problem is solved when the unusual and expected observations are perceived to be the same. Defining a problem is not a trivial task as a problem which is ill-defined is a problem which is unlikely to be solved (see Figure 2).

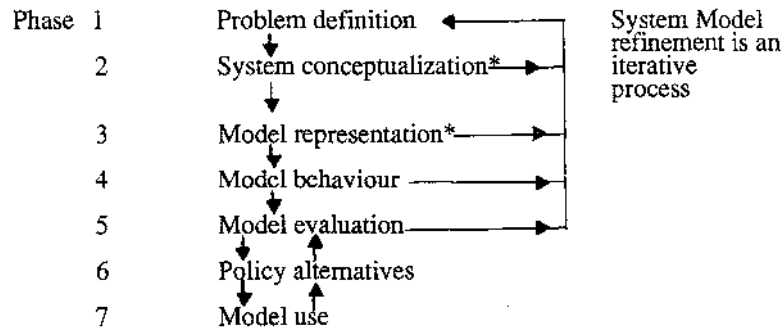

\* includes digraphs and computer flow charts

**Figure 2 Seven phases in system dynamics model building (after Anderson and Richardson, 1980).**

Once the problem has been clearly defined it is necessary to attempt some form of conceptualization of the problem viewed as a system. This second phase of system dynamics conceptualization is an art which depends on the creative imagination of the researcher as well as his/her knowledge of the way in which the system functions. The latter can be gleaned, in part,

from detailed studies in the field or laboratory, by questionnaires or through a thorough examination of previous studies. In a system dynamics approach to causal modelling and simulation this phase of model conceptualization is achieved, in part, by constructing a causal diagram or digraph of the system. (See Figure 5).

Model representation is the third phase of systems dynamics model building. This stage consists essentially of translating the causal diagram into a computer flow chart. A flow chart is a partial representation of the sequence of operations which are necessary to solve a problem. Various conventional symbols are used in flow charting (Wilson, 1981b) but all system flow charts show input to or output from the components of a system; interactions or flows within the system are generally shown by arrow symbols; major components of the system are usually illustrated by rectangles whilst regulators or valve symbols are used to portray the controls operating on flows between the various components of a system. The flows are shown by lines with arrow heads indicating the direction of flow. The flow chart for system dynamics models uses the DYNAMO (DYNAMIC MODELS) conventions. Essentially a DYNAMO flow chart consists of one or more state variables or levels shown by a rectangular symbol; rates of change which are shown by a valve symbol and can only affect a state variable; auxiliary functions and parameters are shown by large and small circle symbols respectively. These sets of symbols can be used as a diagrammatic representation of a DYNAMO program. Further details of DYNAMO flowcharting and programming will be discussed in section III of this CATMOG.

In the fourth phase of model building the behaviour of the simulation model is compared qualitatively and quantitatively with the behaviour of the system of interest's reference mode. The reference mode represents either an empirical trajectory of one or more state variables through time or a hypothesised mode of behaviour which the model builders would like the real system to achieve. In the case of basic science a system dynamics model is judged to be verified if the simulation model is able to replicate the actual pattern of the system of interest in a qualitative and quantitatively reasonable fashion. At a qualitative level the model may be verified if the magnitude and the timing of turning points of the state variables correspond closely with the behaviour of the real system. The degree of correspondence between the simulation model and the real system can be measured using the appropriate statistical techniques (see section IV). In the case of soft systems, however, the reference mode is more problematic. Often the actual trajectory of the real system is not known and, to make matters more difficult, the future state of the system depends more on social value judgments than on matters of fact. As in other cases of forecasting a future trajectory of a system depends in part on the way in which we model the system of interest as well as on the level of confidence about our resulting anticipations (Bennett, 1980). Again, however, qualitative and quantitative evaluation of the model might be undertaken as far as possible, especially if the model is to be used as part of the process of environmental management and planning.

Model evaluation is the fifth phase of model building and it is crucially important that parameter sensitivity tests and careful calibration are undertaken as well as rigorous forms of verification procedures used including statistical analyses. In the past the verification of system dynamics

models has been poorly developed although recently there have been some developments in this important area (Legasto et al, 1980; Stennan, 1983). One of the reasons for the debate between system dynamicists and other model builders is the disagreement over the types of verification procedures to be used. These fundamentally important issues will be discussed in section IV. At present, however, it is sufficient to comment on the fact that in complex, non-linear, multi-feedback dynamic systems conventional statistical techniques are NOT the only form of model verification nor are they the most appropriate way in which system dynamics models can be evaluated. It is, however, important to note that system dynamics modelling, as in other forms of systems modelling, is an iterative process. It is often essential to refine the operational model by carefully repeating the first five phases of model building. Often refinement of the model is enhanced when quantitative analyses are used.

The penultimate phase of system dynamics model building, is concerned with the assessment of various policy alternatives. In the original use of the systems dynamics approach much emphasis was placed on the control and management of industrial and urban systems (Forrester, 1961, 1969). This emphasis on policy orientated research is still much in evidence. As Forrester notes, the ultimate test of a system dynamics model lies in identifying policies that lead to improved performance of the real system' (Forrester and Senge, 1980, 224). Despite the difficulties and ethical, as well as political, implications involved in actually carrying out such tests it is clear that many system dynamics model builders have overstressed the various policy alternatives embedded in system dynamics models at the expense of more rigorous research into their own models. It should, however, be obvious that if dynamic models are to be used as tools for implementing environmental management or other aspects of socio-economic planning then it is essential that the model on which some of the policies may be based are sound. If there are major weaknesses in the models then clearly any policy recommendations based upon them must carry little or no conviction (Wilson, 1970).

The final phase in system dynamic modelling is to use a well validated and stringently tested model in order to contribute to an understanding of a particular problem. In basic science this understanding may lead to an efficient and effective solution to the problem. In policy orientated systems, however, this understanding may lead to political ways to promote system change and evolution. If policies emanating from dynamic models are put into practice then it is essential that the real world system is carefully monitored to enquire into the ways in which the policy is effective. This does, of course, raise important questions concerning the ideology of control in the use of system dynamics modelling or other techniques (Gregory, 1980).

(ii) Causality and causal models

System dynamics is a form of causal modelling. It is, therefore, important to understand what is implied by the term causality' (Harvey, 1969). Causality implies three things: covariation, temporal precedence and production (Pringle, 1980). If variable Y is said to be caused by X when variations in X are associated with predictable changes in Y, then X and Y

show covariance if all other things are equal. For example, if all other things are equal, then areas with high rainfall (X) should be subject to more flooding (Y) than areas of low rainfall. The term causality also implies temporal precedence insofar as, if event X occurs, then event Y should follow. One would expect flooding, to follow high rainfall rather than vice versa. The third aspect of causality namely production is difficult to prove, although every causal model implies that a change in X produces Y. Note that these two events are not merely correlated but are actually functionally related. It is this emphasis on functional relationships which makes careful causal modelling a fundamentally important aspect of the system dynamics approach to simulation modelling. Failure to identify a sound causal structure of a specific system of interest can result in a misleading simulation model. It is, therefore, important that we examine causal modelling in detail.

In order to classify the hypothesised causal relationships between a number of variables in an environmental system it is useful to represent these relationships diagrammatically. A causal relationship is usually represented by a one headed arrow in which the direction of the arrow indicates the direction of the causal link as shown in figure 3. If no causal connections exist between X and Y then they are not connected as in case (a). In case (b) event X is believed to be a cause of Y. In case (c) Y causes X whilst in (d) X and Y are linked in a reciprocal manner which represents a feedback loop. In a feedback loop a change in X causes a change in Y which in turn causes a variation in X or vice versa. In system dynamics these feedback mechanisms form the basis of the causal models rather than simple unidirectional causal pathways.

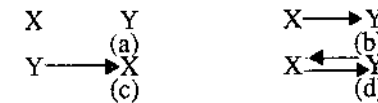

Figure 3 Types of causality (after Pringle, 1980).

If the direction of causal links is ignored then the number of causal links increases rapidly with the number of variables (V). In general the maximum number of possible links or degree of connectance (P) is given by

$$P = \frac{1}{2} V(V-1)$$

If there are no reciprocal links and the causal sequence of the variables is known for each link there are two possibilities either the link is absent or present. Hence, the number of possible configurations C is given by

$$C = 2^P$$

It has been noted that there are V! (V factorial) ways in which V variables may be ordered, and for each ordering there are C configurations. Then the maximum number of possible links for V variables approaches CV! As Pringle notes 'the chances of discovering the correct (causal) model decreases rapidly as the number of variables is increased, therefore one should try to keep hypothesized models as simple as possible whilst ensuring that no major variable has been inadvertently omitted (Pringle, 1980, 7).

### (iii) Feedback loops

Given the vast number of possible linkages in a causal model of a real world system it is important to try and keep the causal model as simple as possible yet still provide a meaningful explanation of the environmental problem. In the system dynamics approach to causal modelling feedback loops form the central structures that generate change in models of a real system. It is assumed that the major changes in the system are generated from the interaction of variables embedded in feedback loops within the boundaries of the model of the system. Several implications flow from this strict assumption. First, it is vitally important that the structure of the model is an accurate and simple portrayal of the real world problem made at an early stage in the model development process shown in Figure 2. Failure to give an adequate representation of the system of interest can result in major conceptual changes and re-structuring of the model at a later stage in the model development process. This re-structuring can be expensive in terms of effort, time and computing costs. Next, as environmental scientists and geographers are dealing with open systems (i.e. with systems which have a continuous flow of energy, matter or information across the boundaries of the system) it does not follow that exogenous variables can be ignored. Forcing functions such as random events can be injected into the model to see how it responds to these changes. Nevertheless, the focus of change within the system dynamics model is based upon endogenous changes generated in multi-feedback loops which often contain non-linearities.

Any dynamic model begins at an initial value for each state variable or major component of that model. The initial state then changes through a transient phase in which the pattern of growth or decline of the numerical value of the state variable changes due to causal processes operating on the compartments of the model. In many cases a dynamic model reaches a state of dynamic equilibrium or steady state in which the numerical value for a state variable remains constant through time or oscillates randomly around an average value of the component. Often models illustrating dynamic equilibrium can be maintained in this state despite exogenous changes to the model. These exogenous changes simply displace the model from a state of dynamic equilibrium for a short duration but the model quickly recovers to regain its equilibrium value. The time taken to regain this equilibrium state is known as the relaxation time. These definitions are illustrated in Figure 4 which shows the trajectory or path of one state variable in a model of a dynamic system.

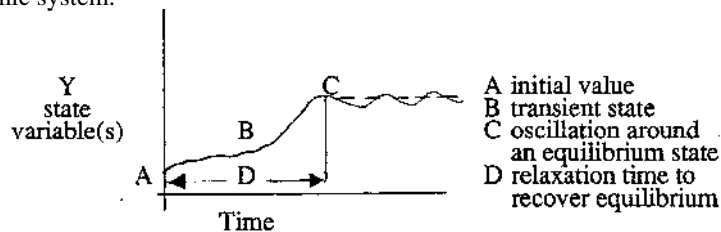

**Figure 4** The trajectory of a state variable to a state of dynamic equilibrium.

Two types of feedback have been distinguished, namely, positive and negative loops. In a positive feedback loop a disturbance to any variable in the loop can reinforce the behaviour of the loop. If a system is in a condition of dynamic equilibrium then a disturbance in a positive feedback loop can cause the whole system's behaviour to grow or decline from the equilibrium point. A positive or self-reinforcing loop tends to amplify any disturbance generated, either by endogenous or exogenous functions to produce exponential growth or decline. In a negative loop, however, an alteration to a variable in that loop can cause the system to fluctuate around or to return to a condition of dynamic equilibrium. Often negative feedback loops are used as cybernetic or control systems and can be most important in generating policy option controls in a model of an environmental system.

An example of a positive and a negative feedback loop is given in figure 5. In the case of a positive loop the diagram can be read as 'the more people there are, the more births there will be; the more births there are, the more people there will be'. The + sign at each arrowhead indicates that the entire loop is positive. Note the same diagram could also be read as 'the fewer people there are, the fewer births there will be; the fewer births there are, the fewer people are added to the total population'. Obviously, in the latter case the population may decline if all other influences are ignored. The positive sign in parentheses indicates the entire feedback loop is positive.

In the negative loop, shown in figure 5b, the number of deaths increase as the total population increase; but as the number of deaths increases the total population may decline. Obviously, if all other things are equal, then the total population will eventually become extinct. Again, the negative and positive signs at the arrowhead show the direction and nature of the causal arrows. Whilst the negative sign in parentheses shows that the overall structure of the feedback loop in this model is negative.

Generally, system dynamics models are composed of several positive and negative feedback loops which form multi-loop systems. By simply combining the positive, and negative loops shown in Figures 5(a) and (b) a crude model of population dynamics can be made as seen in Figure 6.

This model could, of course, be developed further to show different population cohorts by age as well as to illustrate the various determinants of population dynamics. A more complex causal diagram of population dynamics is illustrated in Figure 6b.

In this model the total population (POP) has been subdivided into four population cohorts with the corresponding mortality rates as negative feedback loops in the system. The number of births and maturation rates (MAT 1, MAT 2, MAT 3) form positive causal arrows and would cause the population to grow if the vital rates are greater than the death rates. As in the earlier simple model (Figures 5 and 6a) this model excludes migration (Madden and Moffatt, 1979) and any links with the resource base which are vital components of a realistic demographic model. Obviously the causal diagrams we develop can become increasingly complicated but it is necessary at this juncture to be able to progress from drawing causal models to build operational versions of these causal diagrams or digraphs.

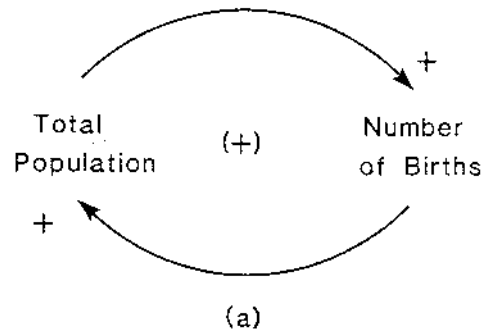

(a)

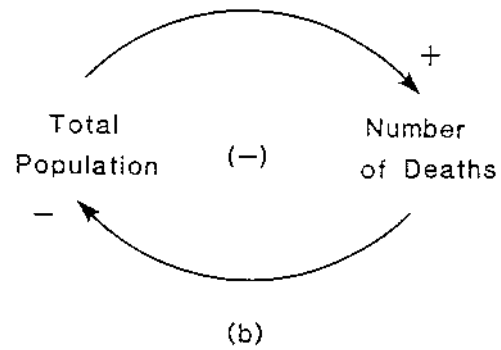

(b)

Figure 5. Causal diagrams illustrating positive and negative feedback loops.

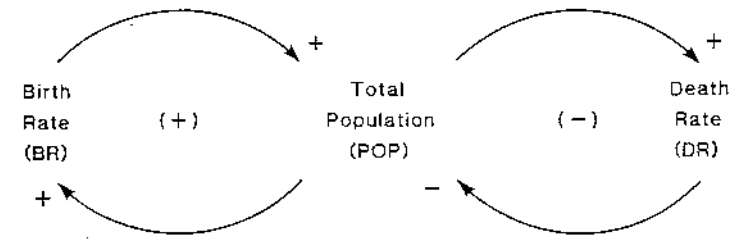

Figure 6a A population dynamics model.

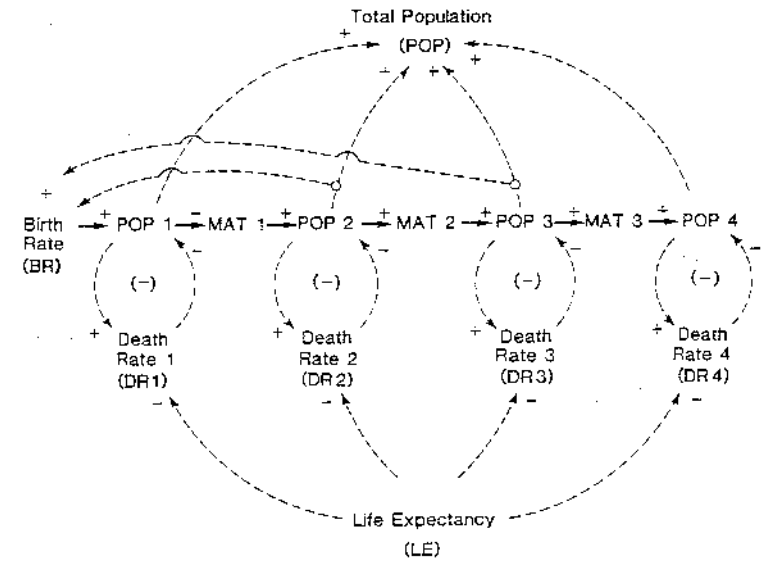

Figure 6b A four age cohort demographic model (see text for explanation).

### III COMPUTER SIMULATION AND QUANTITATIVE SYSTEM DYNAMICS

#### (i) From digraphs to DYNAMO flowcharts

One of the pedagogic advantages of using the system dynamics approach to computer simulation modelling is that it is a relatively simple task to translate a causal diagram into a DYNAMO simulation model. Only two steps are involved in this translation, namely, the completion of a DYNAMO flow chart and then transcribing this flow chart into a computer program using the DYNAMO computer simulation language or other languages such as NDTRAN or DYSMAP (Pugh, 1976; Stewart and Ratnatunga, 1977).

A DYNAMO flow chart is an illustration of the postulated relationships between the various elements of a system. It depicts the assumptions with a degree of detail somewhere between the dynamically suggestive, but incomplete, digraph or causal diagram, and the detailed, precise instructions written in DYNAMO. The following example illustrates the way in which a digraph can be translated into a DYNAMO flow chart

Consider the growth of populations depicted in Figure 7. If it is assumed that no migration occurs in this system of interest then it is obvious that the total population increase is due to the net birthrate exceeding the deathrate.

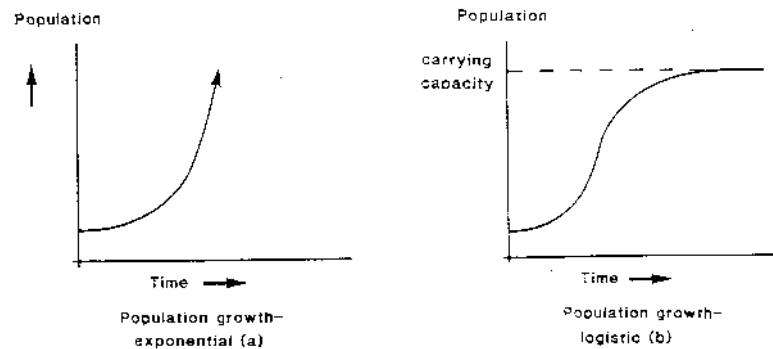

Figure 7 Two trajectories of population growth

If left unchecked this population growth may become exponential (Fig. 7a) but if the system was constrained then population growth may show a logistic form (Fig. 7b). In this section we concentrate on exponential growth and will return to population growth in a constrained system later (cf. Section III iii).

In the case of exponential population growth it is clear that the number of births exceed the number of deaths per unit of time. These two rates of change represent a positive and a negative feedback loop respectively operating on a state variable named POP to represent the total population.

The causal diagram is shown in figure 8 where the birth rate (BR) forms a positive loop; total population (POP) the state variable or level; and the death rate (DR) represents a negative loop.

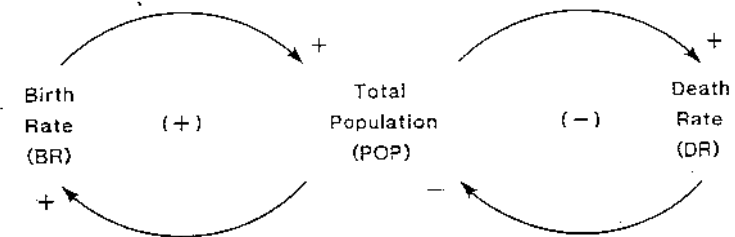

Figure 8 A simple demographic digraph

It is now possible to translate this digraph into a DYNAMO flow chart by using the conventional symbols in this simulation language. In Figure 9, several of the major symbols used in DYNAMO flow charting are illustrated.

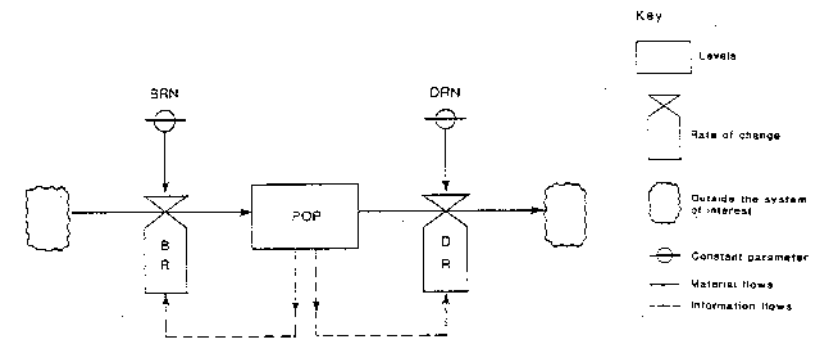

Figure 9 A DYNAMO flow chart of population dynamics.

The state variable or level is represented by a rectangle; the birth and death rates by valve like symbols and the flow of people into and out of this system by births or deaths by two solid lines. The cloud-like symbol represents the boundaries of the system of interest. The two plimsol-like symbols represent constant parameters whilst the broken line represents information flows between the various elements of the system. It is now a relatively straightforward task to transcribe this flow chart into a DYNAMO computer program.

## (ii) Writing a DYNAMO program

In this monograph it is assumed that the reader has access to DYNAMO on a computer for his/her work. DYNAMO is available on DEC VAX 11/780 and IBM 370/380 mainframe computers and micro-computers. A somewhat similar language DYSMAP is used on some ICL mainframe computers. Another language NDTRAN 2 is also available on mainframe computers. Currently DYNAMO is available on several micro-computers such as APPLE II 64k machines with PASCAL interface or on an IBM personal computer in the form of Professional DYNAMO or similar PC clones (Pugh, 1976; Stewart and Ratnatunga, 1977). It is NOT, however, essential to use DYNAMO as many DYNAMO models can be translated into BASIC or FORTRAN which are more widely available on microcomputers or mainframe computers (Jeffers, 1978). The remainder of this section translates the DYNAMO flow chart into a DYNAMO program.

Any DYNAMO statement is written in the following form:  
Type Variable name = expression

A single letter typed into the first column of a program represents the type of equation for example L represents a Level; N an Initial value; C a Constant; R. a Rate; A an Auxiliary and T a Table function. In DYNAMO the basic tool is the integration concept written as

quantity of variable now = quantity of variable earlier + elapsed time x rate of change

As DYNAMO is concerned explicitly with dynamic simulation it is important that time subscripts are used in the program. In DYNAMO the following notation is used: the 'resent time is indicated by subscript K, written as 'variable name.K'; the previous time period by subscript J; and the difference in time between J and K is given by DT. The above equation can now be re-written as:

Type quantity of variable . K = quantity of variable . J + DT\*rate of change

Obviously, it would be cumbersome to write a program with such long variable names. Hence, in DYNAMO any variable is denoted as an abbreviation, usually a mnemonic, followed by an appropriate time suffix, depending on the type of variable. The mnemonic must be no greater than five alpha-numeric -characters beginning with a letter.

In the population dynamic example (cf. Figure 9) it is now possible to write the level equation as follows

$$L \text{ POP.K} = \text{POP.J} + (\text{DT}) (\text{BR.JK} - \text{DR.JK})$$

where L is a level type of equation i.e. an integration

POP - Population  
BR- Birth rate  
DR - Death rate  
DT - the solution time or length of computational interval

There are several important points to note about any level equation. First, a level equation defines a state variable at the present or current time period in terms of its previous value and its change during the time interval  $\Delta T$ . Next, a level equation represents a simple Euler integration technique in DYNAMO in which the rate of change is assumed to be constant during the solution time  $\Delta T$ . In order to minimize the numerical inaccuracies  $\Delta T$  must be chosen at least one half or one-quarter of the size of the shortest temporal delay in the model. Often the value of the shortest time constraint is not explicit in the model, as it is embedded in an inbuilt function in DYNAMO, hence several experiments must be performed in order to determine a satisfactory value for  $\Delta T$  (Pugh, 1976; 1980). Third, the nature of any statement expressed as a level or state variable may range from a single number or variable to a complicated combination of factors and terms involving numbers, variables and functions. Often, these complicated expressions are placed in parentheses. Any expression in parentheses is calculated first, and its value is then substituted for the parenthetical expression. It will be noted in the above level expression that the death rate is subtracted from the birth rate. Generally, the operations of addition, subtraction multiplication and division are denoted by +, -, /, \* respectively. Multiplication and division have priority over addition and subtraction.

In the DYNAMO flow diagram the level (POP) is directly influenced by two rates namely birth rate (BR) and death rate (DR). A rate equation describes how the rate of flow into or out of a level varies, depending on other conditions in the system. All levels are controlled by rate equations. As Forrester states 'rates of flow cause the levels to change. The levels provide information inputs to the rate equations which control the flows. Levels are changed only by rate of flow. The rate variables depend only on information about the levels. No rate can directly affect another rate and no level directly affects any other level.' (Forrester, 1969; p.14; 1961). In DYNAMO a rate equation uses the double letter subscript, JK or KL. The subscript JK represents the previous time interval J to K the present and KL, the next time interval from K to L. Graphically, the alteration of the numerical value of a level by the differences between the rates of flow into or out of the level are shown in Figure 10.

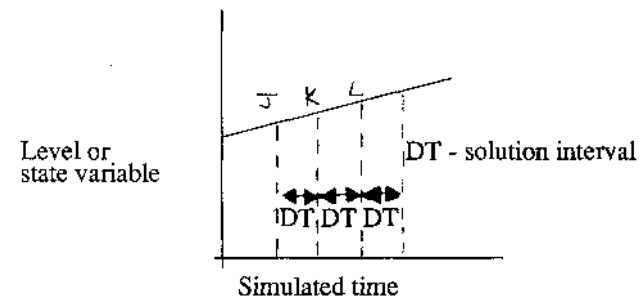

Figure 10 Time subscripts J, JK, KL in DYNAMO

In the case of the demographic model the birth and death rates have the same structure. The birth rate (BR) can be written as

$$R \text{ BR.KL} = \text{POP.K} * \text{BRN}$$

where R is a Rate type of equation  
POP is the Population level at time K  
BRN is Birth rate Normal (a constant)

Similarly, the death rate (DR) can be written as

$$R \text{ DR.KL} = \text{POP.K} * \text{DRN}$$

where DRN is a Death Rate Normal (a constant)

There are two types of constants used in system dynamics. The first, like Birth Rate Normal (BRN), is a numerical value which must be given explicitly in the program as follows

$$C \quad \text{BRN} = 0.001$$

where C is a Constant type of equation

BRN - Birth Rate Normal (set at 1 death/000 people)

The second type of constant is an initial value equation which defines the value of a level at the beginning of the simulation. The variable name in such an equation is the name of the level without time suffixes. Its expression can be a number, the variable name of a constant or a combination of other variables without time suffixes. To initialize the population model the following format is used:

$$N \text{ POP} = \text{POPI}$$

$$C \text{ POPI} = 3000000$$

where N is an iNitial type of equation

C is a Constant type of equation  
POP is the numerical value of the level (POP) representing population

POPI is the population at the initial stage of the model where POPI is set, in this case, arbitrarily at 3 million people.

The entire DYNAMO program for the population growth model given in Figure 9 is presented in Table 1. It will be noted that in any computer program a clear layout is essential. In DYNAMO the use of either NOTE or \* in column 1 is useful to describe the contents of the program or some aspect of it (lines 10 to 60 inclusive). Like the REM statement in BASIC the computer ignores anything that follows a NOTE or \* line (see line 140). The body of the computer program is given by lines 70-130 inclusively. Note, however, that unlike BASIC line numbers are NOT typed into the program. The output for the program is called up in lines 150-180 inclusive. The specification or SPEC of the duration of the simulation is given as length; the

solution interval DT is set at unity but most of these parameters can be altered. The PLOT or PRINT lines actually plot and print the information required, in this case the population at each interval for 50 temporal units. They are invoked by using the inbuilt DYNAMO functions PLTPER (for plotting) and PRTPER (for printing) in the SPEC line 150.

---

```

10 NOTE AN ELEMENTARY DYNAMO PROGRAM
20 NOTE TO ILLUSTRATE THE DYNAMO SIMULATION
   LANGUAGE
   0 NOTE POPULATION DYNAMICS MODEL
430
50
60 NOTE POPULATION SECTOR
70 L POP.K=POP.J+(DT)(BR.JK-DR.JK)
80 N POP=POPI
90 C POPI=3000000
100 R BR.KL=POP.K*BRN
110 C BRN=0.0015
120 R DR.KL=POP.K * DRN
130 C DRN=0.001
140 NOTE CONTROL CARDS
150 SPEC LENGTH=50/DT=1/PLTPER=1/PRTPER=1
160 PLOT POP=X
170 PRINT POP
180 RUN STD

```

N.B. line numbers are NOT typed into the program which begins with a type statement e.g. L in line 70.

**Table 1 An elementary DYNAMO program**

### (iii) Logistic growth model

In many realistic system dynamics models the feedback loops are interconnected in a complex way by use of auxiliary equations. An auxiliary equation can contain constants, levels, auxiliaries and table functions. Often auxiliaries can represent either hypothesised or empirically determined relationships which may be linear or non-linear. Furthermore, the behaviour of a realistic multi-feedback non-linear system can be made more complex by incorporating temporal delays in the structure of a feedback loop (see Pugh, 1980 for details). In order to illustrate the use of auxiliary equations and table functions in a system dynamics model the original population dynamics model which showed exponential growth, will be altered to show a logistic form.

The structure of this new population model is presented in the digraph in Figure 11. Unlike the previous elementary model of growth a new feedback loop has been incorporated into the structure of the model. This feedback loop is negative and incorporates the assumption that as the carrying capacity of the area is approached there is a dramatic fall in the birthrate. This assumption could, of course, be challenged as death rates could increase or both sets of actual rates may change. Nevertheless, for illustrative purposes, it is assumed that only the birth rate declines.

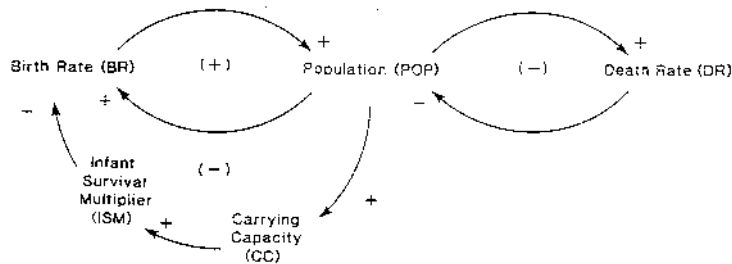

Figure 11 A digraph of a new model of population dynamics

As in the previous worked example it is relatively easy to translate the digraph into a flow chart as shown in Figure 12. In this new loop in the flowchart new auxiliary and table functions are introduced whilst the rest of the model remains the same as in the previous example.

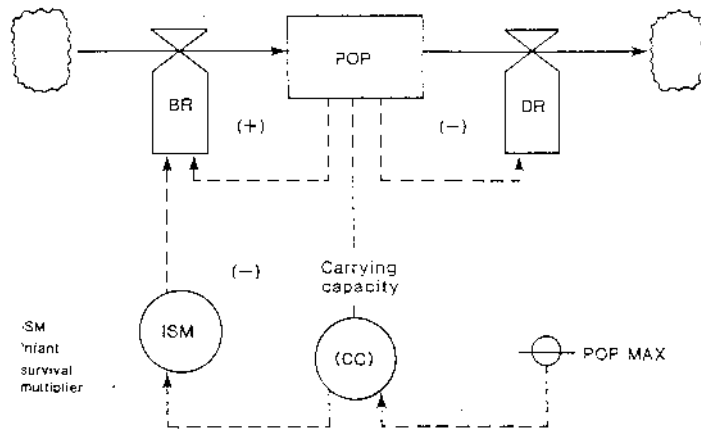

Figure 12 A DYNAMO flowchart of the new model of population dynamics

The new flow chart shows that as the population total increases (POP) then the carrying capacity (CC) of the area is approached. As the limit to the carrying capacity is approached then this has an impact on the infant survival rate (ISM) which in turn reduces the birthrate (BR).

The way in which the new auxiliary table function operates in the model can be explained as follows. The auxiliary equation (CC) represents the carrying capacity of the area i.e. the total number of people which can be supported at a given level of material welfare. The limit of this carrying capacity is given by the constant parameter, (PMAX). The constant is set at five million in the model but, of course, in a real study an exact value is required. The relevant lines of the program in DYNAMO are given as

```
131 A CC.K=(PMAX-POP.K)/PMAX
132 C PMAX=5000000
```

where A is an Auxiliary equation

CC is carrying capacity  
 PMAX a constant set at 5 x 10<sup>6</sup>  
 POP is total population in the level

The table function is a simple device for 'looking up' the values of a dependent variable as a function of an independent variable over a specified range. The dependent variable and its range are specified in an auxiliary equation preceding the table. In a digraph table functions are shown symbolically by using two parallel lines (indicating a table function) cutting horizontally through an auxiliary symbol (shown as a circle). The following example illustrates the relationship between the Infant Survival Rate value and carrying capacity.

```
133 A ISM.K=TABLE(ISMT,CC.K, 0,1,.25)
134 T ISMT = 1.00/0.9510.88/0.78/0.00
```

Table functions are quite powerful devices for representing linear or non-linear relationships in a simulation model. Complex non-linear relationships can be shown by using polynomial forms using 'FABPL. If the range of values exceeds the limits of the table function then the highest and lowest values in the table will be used if the function TABHL is used (see Pugh, 1976 for details). In the above example the term ISM represents the infant survival multiplier rate which descends as the carrying capacity increases from a low value to unity. In this example the actual value for ISM is given by interpolating the straight line values between successive points on the curve given by the function ISMT. As the DYNAMO compiler uses a linear interpolation for values of ISMT between the specified points it is important to use a small step size to increase the accuracy of the model as shown in Figure 12. It is also important to note that the relationships embedded in a table function may be determined from empirical research or could be completely hypothetical. If hypothetical relationships are assumed in a system dynamics model then it is essential that the model builder indicates the tentative nature of these relationships. As Radmaker notes, 'The analysis of any system should always be conducted in such a way that the

consequences of the weakest assumptions are kept in sight as much and as long as possible, but unfortunately, most system analysts lose track of their assumptions almost as soon as these have been introduced'. (Radmaker, 1974, 75).

Only one further amendment to the original program is required for it to work. It will be recalled from the digraph and the flowchart that the infant survival multiplier has an impact on the birthrate (see figures 11 and 12). Hence, line 100 should be replaced to show this relationships viz:

$$100 \text{ R BR.KL} = \text{POP.K} * \text{BRN} * \text{ISM.K}$$

It must be noted that in DYNAMO there are no line numbers, as in BASIC, the first entry on any line being a type identifier e.g. R for Rate in the above equation.

#### (iv) Difference equations and system dynamics

The growth of population examples discussed in sections ME and Illiii represent very simple dynamic models. Both of these models have one state variable or level namely population (POP) and two rates representing birth and death rates (BR and DR) respectively. The DYNAMO flow chart and program clearly show the structure of this model which is based on a single difference equation. A difference equation relates a dependent variable, say POP in terms of the difference between that value of POP at one instant and the next time period. A first order difference equation can be written as

$$\text{POP}_t = a \text{POP}_{t-1}$$

where POP is the dependent variable, a is a constant and the subscripts t and t-1 represent the current and previous time period respectively. The above equation is a first order difference equation as it involves only the previous time period. A second order difference equation involves a lagged relationship between two time periods

$$\text{POP}_t = a\text{POP}_{t-1} + b\text{POP}_{t-2}$$

where b is another constant and t-2 is an earlier time period. In complex system dynamics models third and higher order difference equations are used to simulate real world systems.

The use of difference equations in the system dynamics approach to simulation modelling can be appreciated in the following graphical example. In Figure 12 the growth of population (POP) is shown as an inflow of births minus an outflow of deaths. These 'flows of people into and out of the system may be labelled birth rate (BR), and death rate (DR). Hence a difference storage equation for the population can be written as

$$\frac{\Delta \text{POP}}{\Delta t} = \text{BR} - \text{DR}$$

where  $\Delta \text{POP}$  is the change in population size during a time interval  $\Delta t$

The transport laws which define the flows of people as birth and death rates can be set up if it is assumed that each rate is proportional to the size of the population. Hence, the specific birth rate, that is, the number of births per unit of the population per unit time can be estimated from the relevant census returns and written as

$$\text{BR} = b\text{POP}$$

where b is the specific birthrate. Similarly, the death rate can be defined as

$$\text{DR} = d\text{POP}$$

where d is the specific mortality rate that is the number of deaths per unit of the population per unit time.

Substituting the definitions for birth and death rate (BR and DR) in equation 1 gives

$$\frac{\Delta \text{POP}}{\Delta t} = b\text{POP} - d\text{POP}$$

which can be re-written as

$$\frac{\Delta \text{POP}}{\Delta t} = (b-d)\text{POP}$$

The difference between the specific birth and death rates (b-d) is called the specific growth rate of the population termed r. This growth of population can be seen graphically in Figure 13. It is obvious that  $\Delta \text{POP}$  is a small difference and can be written as

$$\Delta \text{POP} = \text{POP}_{t+1} - \text{POP}_t$$

where  $\text{POP}_{t+1}$  is the population at t+1 and  $\text{POP}_t$  is the population a time t. Similarly, the time interval  $\Delta t$ , is equal to (t+1)-t. Therefore, the equation may be expressed as a first order difference equation

$$\text{POP}_{t+1} = \text{POP}_t + (r\text{POP}_t)\Delta t$$

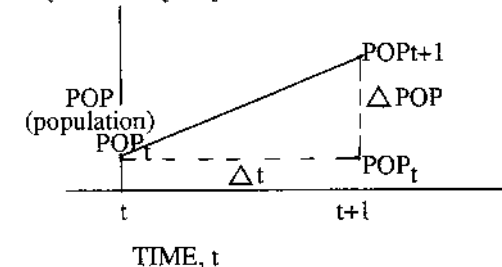

Figure 13 Graphing the population increase,  $\Delta \text{POP}$ , during a time interval,  $\Delta t$

This model of population growth is identical in structure to the DYNAMO level equation given in Table 1 line 70. Both formulations represents first order difference equations of a simple population growth model that is, as yet, uncalibrated.

In order to use the population models the initial value for POP must be given ( $32.52 \times 10^6$  for England & Wales 1901) and the length of the simulation as well as the solution time (DT) must be written into the program. Table 2 lists the results of several simulations using the exponential and logistic population growth models. Obviously the degree of correspondence between the predicted and actual patterns depends on the accuracy of the parameters of the model as well as the step size or solution interval (DT). **Using** DT=1; BR=0.0065; DR=0.001; PMAX= $60 \times 10^6$  the logistic and exponential models give a reasonable fit with the real world data. (table 2 columns 4 and 5).

Date	Decades (t)	Actual or Observed Population x 10 <sup>6</sup>	Exponential Model Predicted Population x 10 <sup>6</sup>	Logistic Model Predicted Population x 10 <sup>6</sup>
1901	0	32.52	32.52	32.52
1911	1	36.07	34.35	34.12
1921	2	37.88	36.29	35.81
1931	3	39.95	38.34	37.62
1941	4		40.49	39.54
1951	5	411.475	42.78	41.57
1961	6	46.10	45.19	43.74
1971	7	48.85	47.74	46.06
1981	8	49.16	50.43	51.14
1991	9	--	56.28	53.94
2001	10	--	56.28	53.94

**Table 2 Results of the exponential and logistic population growth model for England and Wales, 1901-2001.**

There are, of course, several weaknesses in the model structure. First, migration is excluded in both the logistic and exponential growth models. Next, both models assume that the initialization of the level (POP) is accurate but it may be in error. Third, the exponential growth model assumes a fixed birth and death rate. This assumption is flawed on two counts namely the accuracy of the birth and death rate constants. More seriously it is known that in several Western countries the birth and death rates have altered through time. These alterations, known as the demographic transition, are not incorporated into the structure of the model although they have been included in more detailed models. Finally, both dynamic models are sensitive to change in the solution interval (DT) - the smaller the value the more accurate the model.

In the case of the logistic model the hypothetical nature of the infant survival multiplier and its links with carrying capacity would need to be examined in greater detail. Similarly, the degree of fit between the predicted and actual population size would need to be compared using a variety of techniques of verification (see section IV).

### (v) The mathematical basis of all system dynamics models

One of the major advantages of computer simulations is that they combine the strength of the human mind and the power of today's computers to tackle complex, dynamic problems. Obviously, computer simulations are only used when the problem cannot be solved by use of appropriate analytical techniques. In this chapter it has been shown that the methodology of system dynamics is a careful reflection of the underlying difference equations which are believed to give a useful representation of a particular system of interest.

At first sight the causal diagrams or digraphs are similar to those used in other approaches to systems modelling. A moment's reflection, however, will reveal that system dynamics causal diagrams focus on complex feedback loops. These feedback loops may contain many delays which ensure that the mathematical formulation of the operation of simulation models contain second, third or higher order difference equations. One of the advantages of using difference equations is that it permits researchers to deal 'numerically or on a computer with a finite number of points and with the differences between values at these points' (Wilson and Kirkby, 1980, 187).

By translating the digraph into a DYNAMO flow chart the model builders mental or verbal model of the system is made transparent and the structure of the difference equations is clearly revealed. This revelation is observed in the unusual symbols used in DYNAMO with the levels or state variables representing a method of integration; the rate symbols representing changes from one time interval to the next; the auxiliary equations, including table functions and constant parameters, help to clarify the processes whereby a change in one level influences another level via the rate equations.

In general terms, then, any system dynamics model is a completely recursive set of difference equations consisting of k level equations, n auxiliary equations, m switching equations and rate equations ( $m \geq k$ ). The level equations are linear combinations of the rate variables. The rate equations are arithmetic but can often contain auxiliary equations. These auxiliary equations are arithmetic, linear or non-linear table functions are also completely recursive. A recursive system of equations is solved by calculating the values of the state variables at the next time period from the values of the same variable for an earlier period. The switch functions are univariate, binary switches which can alter the rate equation. These switch functions may include behavioural, homeostatic feedback controls and are often used in examining policies embedded in the models. A homeostatic control is one which maintains a system in a state of dynamic equilibrium by the operation of one or more negative feedback loops. In the case of dynamic modelling for environmental management the decision maker can attempt to control the model of a specific system by using negative feedback loops as 'levers' for the application of particular policies.

With regard to the mathematical basis of system dynamic models Day remarked that, 'to the mathematically initiated the approach appears to disguise what is a logically conventional and relatively simple class of dynamic models. To the general scientist who lacks or does not prefer conventional mathematical tools, the approach offers a rigorous, flexible and intuitively appealing, though limited, methodology' (Day, 1974, 126). In short the methodology of system dynamics is a systematic, consistent and carefully constructed, elementary approach for building linear and non-linear dynamic simulation models which can be of use for examining environmental problems.

## IV MODEL EVALUATION AND SYSTEM DYNAMICS

### (i) Model evaluation

The words 'validation' and 'verification' are often used differently by different writers. Here, validation refers to a consistent, internal logical structure of a model, whilst verification refers to the various ways in which a model's behaviour can be compared with the real world system. In the past system dynamicists have, by and large, paid too little attention to subjecting their models to various types of verification procedure. This has led to a host of methodological criticisms (Nordhaus, 1973; Forrester et al, 1974; Legasto, 1980) which have done little to persuade other researchers about the usefulness of the system dynamics approach to causal and simulation modelling.

In particular quantitatively orientated researchers have bemoaned the fact that statistical techniques are rarely used to evaluate the numerical accuracy of system dynamic models; the reply that 'conventional statistical tests of model structure are not sufficient grounds for rejecting the causal hypotheses in a system dynamics model' (Forrester and Senge, 1980, 217) has some truth to it but it does not follow that all statistical tests can be abandoned in favour of arguments over plausibility of the models. Fortunately, this deplorable state of affairs has been re-examined and several system dynamic model builders have proposed series of tests which can be used to evaluate a system dynamic model. These tests are listed in Table 3.

#### Model structure

- a structure validity
- b boundary adequacy
- c extreme conditions and dimensional adequacy

#### Model behaviour

- d parameter verification and sensitivity
- e behaviour reproduction and forecasting
- f changed behaviour forecasts

(After Forrester and Senge, 1980)  
**Table 3 Tests for evaluating system dynamics models.**

### Tests of model structure

#### a) Structure validation

A model is judged to have a valid structure if it is internally consistent with the assumptions it is based upon and that these causal structures include the most important feedback loops for understanding the way in which the model and the real system function. Obviously, no causal simulation model could consist of entirely known and empirically verified relationships as the art of simulation modelling is to throw light upon causal relationships which have yet to be subjected to further research and empirical testing. A model is judged to be valid if the following two conditions are satisfied. First, if the model is capable of describing and predicting the behaviour of the system satisfactorily. Next, if changes in policy options embedded in the model produce the desired improvement in the simulation forecast and will produce closely similar improvements when applied to real world systems. This second aspect of model validity can give rise to ethical and political problems (see section V).

#### b) Boundary adequacy

The setting of a boundary around a system of interest is a difficult task. In system dynamics a boundary is set when the model builder is satisfied that all the important interactions via feedback loops actually mimic the behaviour of the real world system. With regard to policy orientated research it is assumed that policies activated in the model can occur within the system boundary rather than be imposed on the system from exogenous inputs. It is important to note that closing the boundary of the system model does not exclude important forcing functions which can be generated exogenously. Hence, many environmental systems, which are by definition open complex systems, are modelled as if the major interactions are contained within the provisional boundaries of the system model. It is only in the later stages of system dynamics modelling that the adequacy of the boundary can be empirically verified.

#### c) Extreme conditions and dimensional consistency

The extreme conditions and dimensional consistency tests are also useful for ensuring a valid structure to a system dynamics model. The extreme conditions test is a very strong procedure for evaluating system dynamics models. This test consists essentially of considering the implications of imaginary minimum and maximum values of each state variable or combination of state variables which through interconnected multi-feedback loops influence a rate equation. The extreme condition test is important for two reasons. First, it can reveal flaws in the model structure by illustrating for example, if a level has a negative value. Next, by examining model behaviour under extreme conditions this can "enhance the models usefulness to explore policies that move the system outside of historical ranges of behaviour" (Forrester and Senge, 1980, 214). Furthermore, in any model it is vital that the dimensions of the state variables and parameters are correctly specified and consistent. Failure to pass this elementary and essential test casts serious doubts on the structure of the model.

## Tests of model behaviour

### d) Parameter verification and sensitivity

In many system dynamics models three types of parameters are generally found: initial values, other constants and table-functions. As initial value parameters are used to set the initial values for all state variables in a model it is important that these should be based on the most accurate data available. Similarly, the numerical value of the constants ought to be as accurate as possible. It is also assumed that the 'constants' are, in fact, invariant during the simulated time period - although when simulating thousands or millions of years of environmental changes the 'constants' may alter. In this case it is best to use table-functions in the model structure.

Table-functions can be linear or non-linear relationships which are based on empirical data or hypothesized relationships. In the former case the usual curve fitting procedures such as linear or non-linear regression should be used to estimate the equation to be the best fit curve for the table function (Ferguson, 1978). In the case of hypothetical relationships it is essential to clearly state the basis for this relationship in the model. In several early system dynamics models, such as Urban Dynamics (Forrester, 1969), all the system-functions were hypothetical. Whilst there is nothing wrong in linking hypothetical relationships into a general theory of, say, urban structure, it is important to attempt to justify both the model's output and some of the hypothetical relationships. As Naylor and Finger note 'simulation models based on purely hypothetical functional relationships and contrived data which have not been subjected to empirical verification are void of meaning ... and such a model contributes nothing to our understanding of the system being simulated' (Naylor and Finger, 1971 p.17)

Multi-loop, non-linear feedback dynamic system models behave in unpredictable ways. This has often led system dynamicists to argue that their models are insensitive to parameter changes. What is actually meant is that system dynamic models are insensitive to most parameter changes. In most cases model behaviour is sensitive to a few points in the system'. (Tank-Neilson, 1980, 1992). It is, however, often difficult to perform sensitivity tests on non-linear models especially when a large number of parameters are involved. Nevertheless, it is possible to perform sensitivity analysis on the models to highlight those parameters that alter the behaviour of the model in a significant way (Tomovic and Vukobratovic, 1972).

Parameter sensitivity tests may be defined as running a simulation model by successively changing one or more parameters in the model and then comparing the model output to determine the effects of the change(s) (Vermeulen and de Jongh, 1977). In many large system dynamics models, accurate values of all parameters are not always known hence the need for much information can be avoided by using the estimated values of these unknown parameters. If the system exhibits a relative insensitivity of these parameters, then the estimated values can be adequate. If, however, the parameters are shown to be sensitive then much more effort should be expended to obtain their more accurate values (Tomovic and Vukobratovic, 1972). An example of sensitivity analysis will be presented in subsection iv below.

### e) Behaviour reproduction and forecasting

One of the principal uses of simulation modelling is to try and mimic the behaviour of a particular system of interest. This behaviour reproduction attempts to replicate the magnitude, turning points and periodicity of the state variables in a system. If the historical trajectory of the state variables is simulated with a reasonable degree of accuracy then an unconditional forecast may be made (Ferguson and Morris, 1987).

Unlike a scientific prediction, which is a single, one-off scenario for a future event, an unconditional forecast anticipates a future state of the system of interest if no action is taken. In Figure 14 a qualitatively, reasonable fit between the predicted and actual system of interest is presented along with an unconditional forecast.

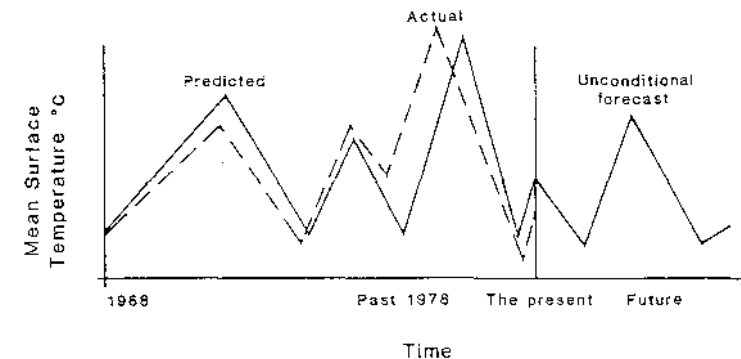

**Figure 14 Actual and predicted temperature change for a hypothetical system.**

### f) Changed behaviour forecasts

Increasingly, environmental scientists and geographers use simulation models to determine the response of the real system to policy actions. These new policy options give rise to changed behaviour of the system and are known as conditional forecasts. These conditional forecasts may alter the trajectory of the unconditional forecast in different ways. Once various alternative scenarios have been simulated, by altering policy options in a system dynamics model, then the 'best' of the alternative policy options available to effect a desired change can be selected. Obviously, the choice of the 'best' option raises technical and ethical problems.

At the technical level system dynamic models can easily incorporate various policy options by using switching functions to turn on a policy at a selected time in the simulation. If, for example, it was felt desirable to check

population growth given in the previous models (cf section DI) then various forms of birth control or increased death rate could be advocated. These 'policy' options would then be switched on during the simulated time period to ensure that, in this case, the population total did not rise above, say, the carrying capacity or a socially desired norm. As in the case of the original model it is, of course, important to determine the sensitivity of these new parameters introduced into the model.

The ethical problem involved in choosing the 'best' decision is much more difficult to resolve than the technical problem - although it does require some technical expertise. Chen and Gamson clarified the issue when they wrote that 'Perhaps the most difficult question for the physical scientist is that of the underlying value structure of the social group being modelled, since value laden questions are usually avoided by physical scientists and technologists ... if public policy planning is basically a bargaining process, then one useful way to extend (system dynamics models) ... will be to adapt its methodology to value orientated social system analysis ... the purpose of modelling on the basis of different values is to identify the optimum policy for each value group, to understand why and where these groups differ fundamentally, to help them communicate with one another, and (one hopes) to generate new policy alternatives that are closer to the present optimum in the bargaining process...' (Chen and Garrison, 1972, p.145).

One useful way to resolve this problem has been made by linking a system dynamics model of, say, urban growth with a simple multi-attribute rating technique to allow value conflicts to be expressed explicitly and numerically (Gardiner and Ford, 1980). In instances where apparently genuine conflicts exist about which policy is best, the technique offers a set of procedures to promote an orderly and rational debate which may in itself reduce policy disagreements. But, it is noted that 'if after all is said and done, decision makers still disagree, we have no suggestion to offer beyond the familiar political processes which allow society to function in spite of conflicting interests' (Gardiner and Ford, 1980, 255).

#### (ii) The use of statistical methods

One of the major criticisms aimed at system dynamics model builders is the failure to use appropriate, formal statistical inference techniques (Zellner, 1980). There are several reasons for system dynamicists to show a reluctance to use statistical methods in evaluating their models. First, two studies have shown that when 10% noise and 10% measurement error are added to the data used in an econometric model, the estimated coefficients deviate from their true values by factors averaging up to approximately 10.0. Many of these coefficients are statistically significant at the 90% level but a model builder unaware of the true values of the data would probably accept, on the basis of the standard tests of significance, equations whose coefficients are far from the true coefficients' (Johnson, 1980, 155; Senge, 1977). These two studies cast doubts on the use of statistical techniques in system dynamics modelling. Next, many of the variables incorporated into a system dynamics model are 'soft' and rely on non-quantitative information. The inclusion of 'soft' variables makes it possible to simulate the structure of the real system of interest but does so at the expense of statistical estimates of these 'data' (Forrester, 1961). Thirdly, as the behaviour of many system

dynamics models is dominated by a few feedback loops, rather than parameters elsewhere in the model, it is essential that the values of these parameters contained in the dominant loops be estimated carefully.

Despite these three reasons for playing down the importance of statistical techniques in system dynamic modelling it is clear that such techniques provide a necessary condition for establishing confidence in the model. In basic science, for example, the process of calibrating a model involves the use of statistical techniques to find parameter values which optimize to the real world situation (Batty, 1976). Similarly, the policy orientated research ex post and ex ante forecasts are compared with the past data or with the actual realisation when the previously unknown future data becomes available. (Bennett, 1980). In either basic science or policy orientated research it is essential that some statistical techniques are used to test the simulation model. Several techniques are available such as goodness of fit statistics (Fotheringham and Knudsen, 1987), or the use of Thiel's coefficient of inequality (Thiel, 1966). This statistic provides a useful measure to highlight the sources of error in the simulation such as bias, unequal variance and unequal co-variance of the models prediction and the actual observed data. The ways in which system dynamics models can be evaluated are discussed below.

#### (iii) Eutrophication: an example of basic scientific research

In advanced industrial countries many natural and artificial waterways have suffered from the processes of eutrophication. The processes leading to eutrophication are quite well known. One of the key processes is that the waterways have been enriched inadvertently with nutrients due to agricultural and industrial productive practices. This nutrient enrichment results in the growth of various forms of algae. In conditions where light energy is too little for green algae to grow then blue-green algae grow. This growth, if unchecked, deprives other aquatic life of oxygen in the aquatic system and can eventually result in the eutrophication of the aquatic ecosystem.

In 1979 an algal growth model was developed for one species (*Oscillatoria agardhi*) with nitrogen as the limiting nutrient (Loogman et al, 1979). As in any system dynamic model the verbal description or word model (Jeffers, 1978) was translated into a digraph, shown in figures 15a and 15b. The digraph shows three feedback loops, two negative and one positive. The first negative loop indicates that the growth of the species is due, in part, to the availability of dissolved nitrogen available (D W) in the rest of the ecosystem as well as influenced by a short-term store of intra-cellular nitrogen in the algae. The second negative loop indicates that as the concentration of particulate nitrogen increases then there is a change of dissolved nitrogen concentration which also affects the change of algal concentration. The positive loop, simply illustrates that the growth of algal concentration is due to a change in algal concentration. This positive loop behaviour is dampened by the two negative loops. The digraph is then easily translated into a DYNAMO flow chart (figure 15b) and program (Table 4).

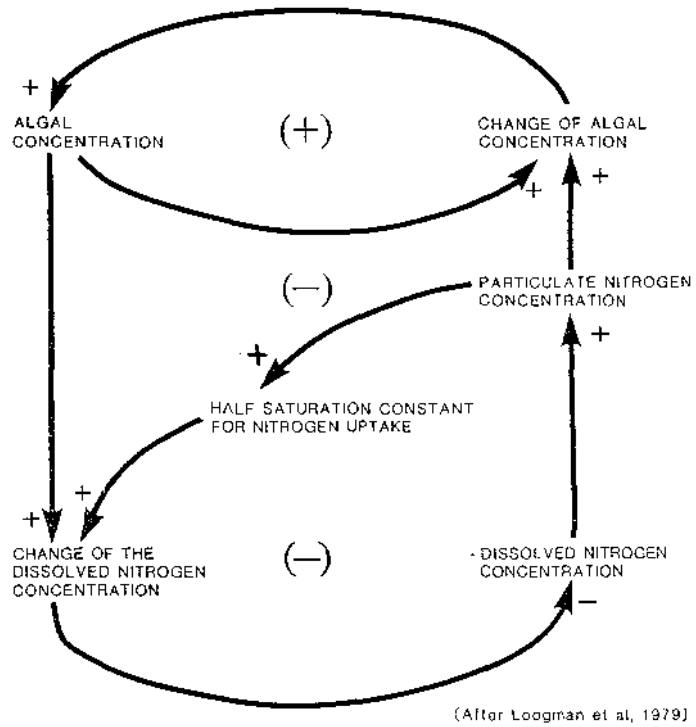

Figure 15a A digraph for simulating algal growth

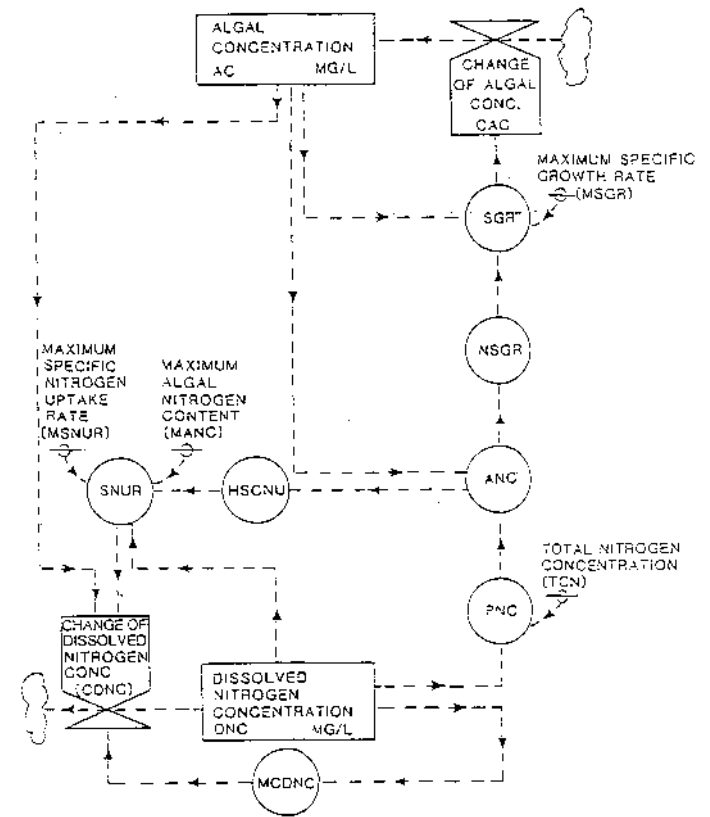

Figure 15b A DYNAMO model of algal growth

```

NOTE ON ALGAL GROWTH MODEL
NOTE AFIER LOOGMAN ET.AL.. 1979
NOTE
NOTE
NOTE ALGAL POPULATION SECTOR
L AC.K=AC.J+(DT)(CAC.JK)
N AC=ACI
C ACI=13
R CAC.KL=AC.K*SGR.K
A SGR.K=MSGR*NSGR.K
C MSGR=0.036
A NSGR.K=TABHL(TNSGRA,ANC.K, 3.25, 4.025, 0.155)+
X TABHL(TNSGRB,ANC.K, 4.025, 11, 0.775)
T TNSGRA=0/0.1065/0.1685/0.2063/0.2343/0.287
T TNSGRB=0/0.1204/0.2139/0.2944/0.3631/0.4306/0.4898/
X 0.5556/0.6259/0.7136
NOTE NITROGEN SECTOR
L DNC.K=DNC.J-F(DT)(CDNC.JK)
N DNC=DNCI
C DNCI=0.5
R CDNC.KL=-MIN(MCDNC.K,SNUR.K*AC.K)
A MCDNC.K=DNC.K.MT
A SNUR.K=MIN((MSNUR.K*DNC.K)/(DNC.K+HSCNU.K),
(MANC-ANC.K+MANC*SGR.K*DT)/(100*DT))
C MANC=11
A HSCNU.K=TABHL(THSCNU,ANC.K,3.25, 11, 1.55)
T THSCNU=0/0.504/0.714/0.861/0.889
A ANC.K=(PNC.K*100)/AC.K
A INC.K=TNC-DNC.K
N TNC=DNCI+(ACI*IANC)/100
C IANC=4
NOTE CONTROL CARDS
SPEC DT=1/LENGTH=120/PRTPER=30/PLTPER=30
PRINT AC,DNC
PLOT AC=1(0, 60)/DNC=2(0, 2)
RUN STD

```

Table 4 A DYNAMO program for Nitrogen Algal Model (See text)

The results of this simple simulation model (Table 5) can then be compared with the relevant data for the growth of algal concentrations taken from laboratory experiments. As can be observed the prediction of the model for algal concentration are in reasonable agreement with the observed data, although the predicted algal concentration is an underestimate after 60 hours, so the agreement with the observed data deteriorates. The data on nitrogen concentration would need to be collected at a finer temporal scale before the predicted result could be verified. As in any model of a real world system several factors have been ignored such as the influence of temperature variations on the aquatic ecosystem. Obviously, these other factors would need to be incorporated in a further cycle of model development so that a more realistic model for the system would be produced (Jorgensen, 1979).

Once a more realistic model is produced the next phase in system dynamics modelling would be carefully to test the model and then, perb.aps, use it as a tool for managing this real world environmental problem. This leads into policy orientated research.

Time in hours	Algal concentration (Mg/L)		Nitrogen concentration (Mg/L)	
	Actual	Predicted	Actual	Predicted
0	13	13	0.5	0.5
30	15	17	0.0	0.3
60	30	25	0.0	0.0
90	35	28	0.0	0.0
120	37	28	0.0	0.0

Table 5 Results of the Nitrogen Algal Model

(iv) World dynamics: an example of policy orientated research

Since the time of Malthus demographers, economists and others have discussed whether or not unchecked population growth can be sustained on this planet (Malthus, 1976; Harvey, 1973). During the period 1970-1974 this problem was again addressed in the well known "Limits to growth" models (Forrester, 1971; Meadows et. al. 1972, 1974). The question that these model builders addressed was defined as: "Will human material activity adjust smoothly to the global carrying capacity or go through a period of overshoot and collapse?" (Randers, 1980, p125). Unlike basic science research which uses an empirically determined reference mode, policy orientated models often use a hypothesised reference mode (Figures 16a and 16b).

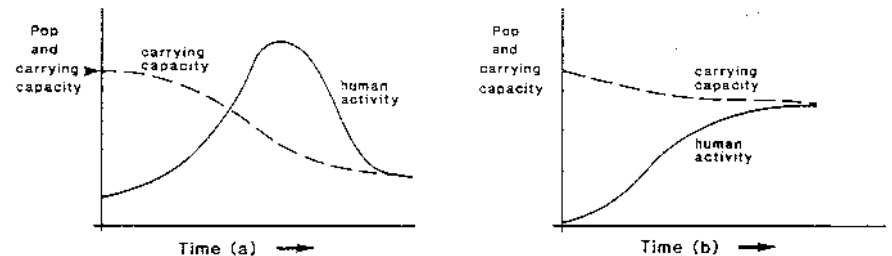
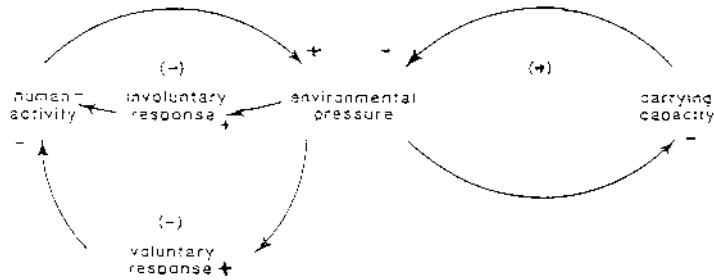

Figure 16 Hypothesised reference modes of the "limits to growth" global models

The argument underlying Figure 16a is that increases in material, human activity eventually erode the carrying capacity of the globe. As human institutions and basic scientific research will be too slow to respond to these changes then an involuntary downward pressure on human activity through, say, starvation occurs so that the much reduced world population can survive within a greatly reduced global carrying capacity. Since this pattern of overshoot and collapse is judged undesirable, the model builders attempted to investigate possible causes of that behaviour and tried to determine how a change in growth policies might achieve a more gradual adjustment so that human societies can live in harmony with the ecosphere as depicted in Figure 16b.

The basic mechanism of this growth in a finite world can be illustrated in the causal model (Figure 17) which represents the smallest set of feedback processes considered necessary to generate the reference mode in Figure 16b. It will be observed that the model consists of three feedback loops one positive and two negative loops. As described earlier it is relatively easy to move from a digraph into a DYNAMO model of the causal structure of the system. Nevertheless in building dynamic models several hours of effort are required to build an operational version of even a relatively simple model.



**Figure 17** The basic mechanisms that underlie the reference mode of Figure 16b

After twenty-person years of involvement the simple model of the 'Limits to growth' was extended and elaborated to become the World 3 model (Meadows et al, 1974). This simulation model of the dynamics of growth in a finite world has twenty-one levels, thirty-eight constant parameters and thirty-seven non-linear table functions. Figure 18 shows two 'World 3' runs which indicate that the reference modes are still intact even though the model is more detailed than the three sector world model portrayed in Figure 17.

By running the complex World 3 model at least three modes of collapse are possible. First, the limits of natural resources are reached which leads to a resource based collapse (Figure 18a). If, however, resources are substituted and a greater stock of resources become available, then this mode of collapse may be delayed long enough for a second mode of collapse to

occur. This second mode is known as pollution collapse whereby human and animate life are extinguished by increases in various forms of pollution. If, however, this pollution collapse is averted by introducing and implementing antipollution legislation then population collapse occurs. In this third form of collapse the human population has exceeded the limits of agricultural production. The spectre of Malthus haunts the world model (Cole et al, 1973; Clark et al, 1975).

In order to prevent such ecocatastrophes from occurring Meadows et al introduced several policies into the simulation model which are designed to prevent the erosion of resources, overcome the pollution problem and bring a deliberate end to material and demographic growth so that a sustainable equilibrium of humankind and the ecosphere can be achieved. This state of dynamic equilibrium can be achieved in the model (Figure 18b). Their prescription for solving the world predicament is clear, implement these policies now or else! As Meadows et. al. put it "The limits to growth on this planet will be reached somewhere within the next one hundred- years ... even the most optimistic estimation of the benefits of technology in the model ... did not in any case postpone the collapse beyond the year 2100" (Meadows et al, 1971 pp.23,145).

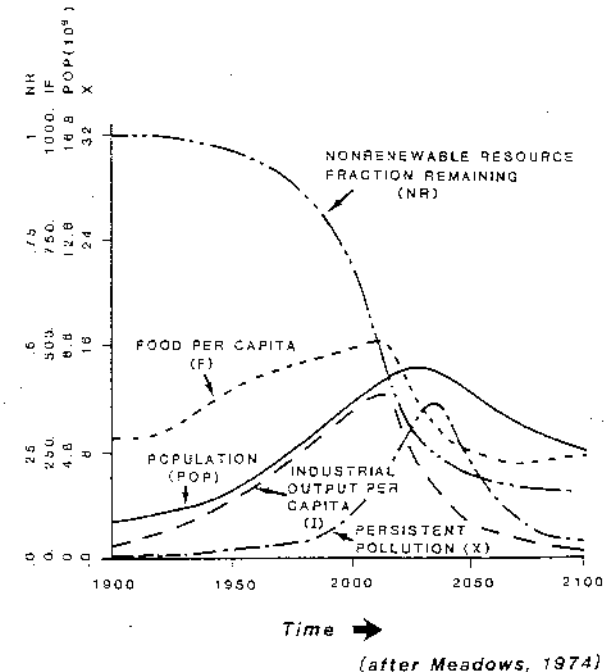

**Figure 18a** World3 reference run  
(This is World 3 reference run. Both population POP and industrial output per capita IOPC grow beyond sustainable levels and subsequently decline)

Given the structure of the World 3 model as well as the large number of parameters contained within it we must ask how confident can one be that the results shown in Figure 18b, and the policy recommendations emanating from the model, are correct? There are, at least, two approaches to this problem. The first concerns model structure and the second is concerned with sensitivity analysis.

With regard to model structure several researchers have suggested that humankind will adapt its institutions and the global environment in order to prevent ecocatastrophes occurring as outlined in the model or in the real world. In 1972 Oerlemans et al suggested that the world model output could be significantly altered by adding a feedback loop in which socio-economic structures respond to perceived and actual changes in the environment and hence the pattern of overshoot and collapse can be avoided (Oerlemans et al 1972). This fundamental change to the model structure assumes, of course, that human institutions and basic scientific work will respond fast enough to avert any ecocatastrophe. This assumption is diametrically opposed to that of the 'Limits to Growth' model builders.

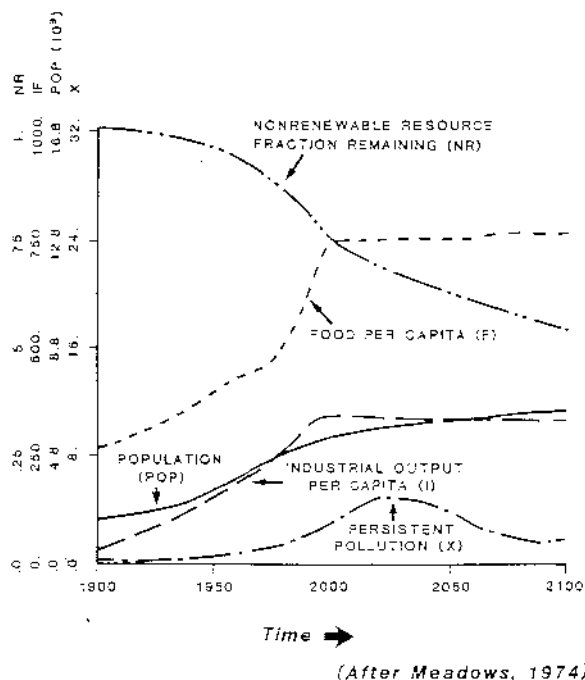

**Figure 18b World 3: equilibrium through adaptive policies**  
 (Adaptive technological policies that increase resource recycling, reduce persistent pollution generation, and increase land yields are combined with social policies that stabilize population POP and industrial output per capita IOPC)

In 1977, a comprehensive sensitivity analysis of World 3 was undertaken in order- to evaluate those parameters which have the most influence on the trajectory of the system. In order to avoid the population collapse of the standard reference run, four changes were made by decreasing every output value of the table function Capital Utilization Fraction (CUF) by 10% of its 1980 value; by decreasing the Average Lifetime of Industrial Capital (ALIC) by 10%; by increasing the Industrial Capital Output Rate (ICOR) by 10%; and increasing the Fraction of Industrial Output Altered to Consumption (FIOAC) by 10% (Vermeulen and De Jongh, 1977).

The results of these small parameter changes prevented population collapse but, in order to achieve this, world industrial output per capita was held back dramatically. The benefits of such a reduction in world industrial output per capita was to keep persistent pollution at a manageable level and the amount of non-renewable resources remained more than double that of the reference run.

Three major conclusions emerge from this critical, methodological study of the 'Limits to Growth' type of models. First, by making a simple change to the original structure -a the World Dynamics model (Forrester, 1973-) it is possible to prevent population collapse. This single change is, however, diametrically opposed to one of the key assumptions made by the 'Limits to Growth' model builders. Next, even if the model structure was accepted as a reasonable representation of the world system, then small changes to the sensitive parameters could change the trajectory of the system without involving drastic changes in this class of world models. As one group of researchers notes the same mathematical model upon which Meadows based his conclusions can be made to yield qualitatively very different results if the values of only some parameters and table functions are changed by as little as 2% each' (Vermeulen and de Jongh, 1977, p.82). Finally, this is not to deny that there are indeed severe environmental problems confronting humankind. There are ecological problems such as desertification and starvation in Africa; these are major economic problems such as enormous international debts confronting many developing nations; there are major political problems associated with the resolution of these problems (Brundtland, 1987). These problems can be tackled in an integrated way by careful basic scientific research coupled with critical and caring managerial practices. It would, however, be unwise to base far reaching policy recommendations on a global scale on such flexible foundations as presented in this class of world models.

## (V) CONCLUSION: THE LIMITS TO SYSTEM DYNAMICS

System dynamics represents one useful approach to causal and computer simulation modelling of the dynamics of environmental systems. The use of system dynamics allows an investigator to explore some deep intellectually challenging problems in basic science such as the transitions of stable models into chaotic regimes. At a qualitative level, for example, the ways in which dynamic systems can move from an equilibrium position through critical thresholds to chaos or to one of several new multiple steady states is a fascinating and little understood problem. These deep problems can tackle issues such as the origin of life on earth and its subsequent

evolution in systems moved far from equilibrium by the continuous flow of energy and matter (Prigogine et al, 1972; Feigenbaum, 1980). Similarly, in urban geography the origin and development of cities can be tackled. In this sense system dynamics does provide another route to aid our understanding of the fundamental theory of dynamic systems. (Wilson, 1981a).

With regard to quantitative research in basic science it is clear that system dynamics in general and DYNAMO in particular represent one coarse approach to match the predictions of a dynamic model with detailed empirical work. This coarseness of quantitatively orientated research is partly due to the errors inherent in Eulers method of integration which can be overcome by using Runge-Kutta or other integration techniques. More important, however is the disagreement over the relevance of statistical techniques when modelling complex, non-linear, multi-feedback models of dynamic systems. This disagreement between users of conventional linear statistical techniques and system dynamicists resides in the quality of the data used as well as in the sensitivity of system models to minor parameter changes in some of the non-linear feedback loops.

Assuming that the structure of a system dynamic model is valid then it is clear that consistent data over several time periods is required for careful quantitative testing of the models predictions. As many system dynamic models are sensitive to small errors in the initialization of state variables and contain sensitive parameters it is important that high quality data, with less than say, ten per cent error in data measurement, be used. This would allow relevant statistical tests to be employed in parameter sensitivity analyses as well as in the careful calibration of a dynamic model. It does, however, impose a very high standard of accuracy in data collection and measurements especially in time series data where the data itself is often woefully inadequate. Clearly, at a quantitative level many basic problems remain to be clarified but, as Langton (1972) points out, these problems 'are no more severe than those which accompany rigorous attempts to understand change through any other dynamic methodology'.

In the domain of policy orientated research such as environmental management and planning the use of system dynamics is intuitively appealing. This appeal is partly due to the ways in which policy options can be embedded in an operational simulation model. These policies, taken singly or in combination, can then be examined and evaluated during successive simulation runs to determine the 'best' policy. Again, at a qualitative level it is relatively easy to make forecasts using system dynamics computer simulation models. These forecasts are worth making because they point towards possible futures. It is, however, very important that the models are robust and, where possible, carefully tested before the policies are actually put into practice. As Hare (1983, p.137) remarks, 'it is the publics privilege to choose politically among these options. But the scientist has to specify the range of possibilities, and the means whereby the goals may be reached'.

It is, of course, vitally important that modellers do not confuse their models of a real world system with reality (Kennedy, 1979). This is extremely important in both basic science and policy orientated research. Kennedy (1979) notes the major theme of some environmental scientists and geographers is to achieve world domination in the most complete and

efficient fashion using system models. Clearly, if this is the goal which many system dynamics model builders are working towards then, as Gregory (1980) points out such system models, if put into practice, are ideological as they secure the reproduction of specific structures of domination of people and the rest of the natural world.

It could, of course, be argued that the goals which several system dynamics model builders cherish are not inhumane or unjust even if they are somewhat utopian. Meadows (1974), for example, suggests that changes in economic, political and social structures may be required in order to create a decent and sustainable standard of living for all. Unfortunately, the ways to achieve this aim are not mentioned, although in the World 3 models several draconian policies are implemented in order to achieve a state of dynamic equilibrium. It has, however, been clearly demonstrated that by making combinations of small parameter changes or by adding another feedback loop these changes can drastically alter the trajectory of the model of the biosphere (Vermeulen and de Jongh, 1977; Oerlemans *et. al.*, 1972). As Postan and Stewart note, 'any social model, verbal or mathematical, thus involves an implicit ideology. Presentations of mathematical modelling of most persuasions attempt to mask this fact' (Postan and Stewart, 1978, 410). Clearly, any attempt to control and plan environmental systems raises deep ideological and ethical problems which if they are to be put into practice will require a substantial effort in addition to formal mathematical modelling.

What then, are the epistemological implications for dynamic system models in environmental management and planning? First, it is obvious that the values embedded implicitly in most dynamic models of environmental systems should be stated clearly (Chen, 1972). These ethical values must include a whole host of views across the political spectrum as well as embodying deep ecological tenets such as those proposed by Naess (1977) who argues that an ecophilosophical position would contain 'both norms, rules, postulates, value priority announcements and hypotheses concerning the state of affairs in our universe'. Next, from the two examples discussed above it is clear that the dynamics of environmental systems offer society two kinds of knowledge. The first provides a scientific framework in order to contribute to our understanding of environmental problems and to have humility about our place and limited power within them. The second type of knowledge has the potential to provide a scientific framework in which we can contribute to the protection and management of environmental problems within these systems (Sagoff, 1985). Clearly, by developing both of these approaches using system dynamics it is possible to understand and manage the causal processes leading to some of the changes in environmental systems. Hopefully, dynamic causal simulation models are contributing to both scientific basic research and immediate policy orientated studies of environmental systems. In many cases this dynamic modelling is orientated towards attaining a just, sustainable and participating form of development as suggested in the World Conservation Strategy (IUCN *et. al.*, 1980; Moffatt, 1983, 1985).

At a quantitative level it is obviously very difficult to make forecasts which, when the data are available, will be shown to be accurate. This difficulty resides in the fact that complex, non-linear multi-feedback, dynamic models can often cross critical thresholds which would drive a model into a chaotic regime and hence produce simulated data which are very

## REFERENCES

different from the real world observations. Another difficulty with making forecasts of the behaviour of environmental systems is that society may respond to prevent such forecasts from being empirically ascertainable. If, for example, the ecocatastrophes presented in the 'Limits to Growth' type models, or in the more recent Nuclear Winter hypotheses, are correct then hopefully these forecasts would never be tested because social feedbacks could prevent such occurrences (Oerlemans, et al, 1972; Ehrlich et al, 1984).

Clearly, system dynamics can be used with various degrees of success in qualitative and quantitative research into basic science and policy orientated problems. Whether these investigations are to further our understanding of, or manage these, environmental systems it is obvious that ethical and ideological considerations must be examined. If, for example, environmental scientists and geographers wished to promote a Just, sustainable and participatory society for all people on the earth then this ethical choice would influence our research priorities and help to advance the aims of the World Conservation Strategy (RJCN, 1980; Myers, 1985) At present, however, many of the system dynamic models are ideological in a narrow sense as they attempt to reproduce specific socio-economic forms of domination for wealthy minorities rather than for the good of all sentient beings on this planet.

In conclusion, then, system dynamics offers a useful approach for tackling environmental problems which can be conceptualised as complex, non-linear multi-feedback dynamic systems. These problems are being tackled by various other approaches and are proving difficult to resolve. The fact that system dynamics offers no easier solutions to these problems of basic science or policy orientated research is not due to the unusual methodology employed in this approach to dynamic modelling but rather reflects the limits to simulation.

- Ackerman, (1963) 'Where is a research frontier?' *Annals of the Association of American Geographers*, 53, 429-40.
- Anderson, D.F. and Richardson, G.P. (1980) *Towards a pedagogy of System Dynamics* In *Systems Dynamics*, eds. A.A. Legasto, J.W. Forrester and J.M. Lyneis (North-Holland Publishing Company, Amsterdam).
- Batty, M., (1976), *Urban Modelling: Algorithms, Calibrations, Predictions* (Cambridge University Press, Cambridge).
- Behrens, J.C. and Sorensen, P.E., (1980), *COLTS (Continuous Long Term Simulation)* In *System Dynamics*, eds. A.A. Legasto, J.W. Forrester and J.M. Lyneis. (North-Holland Publishing Company, Amsterdam).
- Bennett, R.J. and Chorley, R.J., (1978), *Environmental systems: philosophy, analysis and control.* (Methuen, London).
- Bennett, R.J., (1980), *Statistical Forecasting: CATMOG 28* (Geo.Abstacts, Norwich).
- Brundtland, G.H., (1987), *Our Common Future* (Oxford University Press, Oxford).
- Checkland, P., (1984), *Rethinking a systems approach.* In *Rethinking the process of operational research and system analysis*, eds., R. Tomlinson and I. Kiss (Pergamon, Oxford).
- Chen, K., (ed.), (1972), *Urban dynamics: extensions and reflections* (San Francisco Press, San Francisco).
- Chen, K. and Garrison, W.L., (1972), *Urban modelling.* In *Urban dynamics: extensions and reflections*, eds. K. Chen and W.L. Garrison (San Francisco Press, San Francisco).
- Clarke, M. and Wilson, A.G., (1981), *The dynamics of urban spatial structure: progress and problems.* School of Geography, University of Leeds, W.P. 3-13.
- Clark, J. Coles, S., Curnow, R., Hopkins, M., (1975), *Global simulation models: a comparative study* (John Wiley and Sons, London).
- Cole, H.S.D., Freeman, C., Jahoda, M. and Paritt, K.L.R., (1973), *Thinking about the future: a critique of the limits to growth'* (Chatto and Windus, Sussex University)-.
- Day, H. (1974), *System Dynamics: an appraisal.* *Economic Journal*, 14, p.102-126.
- Ehrlich, P.R., Sagan, C., Kennedy, D. and Roberts, W.O., (1984), *The cold and the dark: the world after nuclear war.* (Sidgwick and Jackson, London).

Feigenbaum, J.M., (1980), Universal behaviour in non-linear systems. Los Alamos Science, Summer, 4-27.

Ferguson, R.I. (1978) Linear regression in geography. Concepts and Techniques in Modern Geography. 15. (Geo Abstract, Norwich).

Ferguson, R.I. and Morris, E.M. (1987) Snowmelt modelling in the Cairngorms, N.E. Scotland. Transactions of the Royal Society of Edinburgh; Earth Sciences, 78, 261-267.

Forrester, J.W., (1961), Industrial dynamics (MIT Press, Cambridge, Massachusetts).

Forrester, J.W., (1968), Principles of systems (MIT Press, Cambridge, Massachusetts).

Forrester, J.W., (1969), Urban Dynamics (MIT Press, Cambridge, Massachusetts).

Forrester, J.W., (1971), World Dynamics (Wright-Allen, Cambridge, Massachusetts).

Forrester, J.W., Mass, N.J. and Low, G.W., (1974), The debate on world dynamics: a response to Nordhaus. Policy Sciences, 5, 169-190.

Forrester, J.W. and Senge, P.M., (1980), Tests for building confidence in systems dynamics models. In System Dynamics, eds. A.A. Legasto, J.W. Forrester and J.M. Lyneis (North-Holland Publishing Company, Amsterdam).

Fotheringham, A.S. and Knudsen, D.C. (1987) Goodness of fit statistics. Concepts and Techniques in Modern Geography, 46, (Geo Abstract, Norwich).

Gardiner, P.C. and Ford, A., (1980), Which policy run is best, and who says so? In System Dynamics, eds. A.A. Legasto, J.W. Forrester and J.M. Lyneis (North-Holland Publishing Company, Amsterdam).

Gorz, A., (1980), Ecology as politics (Southend Press, Boston).

Grego, D., (1980), The ideology of control: systems theory and geography. Tijdschrift voor economische en sociale geografie, 81, 327-3-62.

Hare, F.K., (1985), Future environments: can they be predicted? Transactions of the Institute of British Geographers, N.S., 1-0, 2, 131-137.

Harvey, D., (1969), Explanation in Geography (Edward Arnold, London).

Harvey, D., (1973), A question of method for a matter of survival. Department of Geography, University of Reading, G.P. 23.

Huggett, R.J. (1980) Systems Analysis and Geography (Clarendon Press, Oxford).

IUCN, (1980), World Conservation Strategy. World Wildlife Fund.

Jeffers, J.N.R., (1978), An introduction to systems analysis: with ecological applications (Edward Arnold, London).

Jeffers, J.N.R. (1987) Practitioner's Handbook on the modelling of dynamic change in Ecosystems (John Wiley, London).

Johnson, C.B. (1980), Some effects of data error on econometric models. In System Dynamics, eds., A.A. Legasto, J.W. Forrester and J.M. Lyneis (North-Holland Publishing Company, Amsterdam).

Jorgensen, S.E. (ed.), (1979), State-of-the-Art in Ecological Modelling (Pergamon, Oxford).

Jorgensen, S.E., (1986), Fundamentals of Ecological Modelling (Elsevier, Holland).

Kennedy, B. (1979), A. Naughty World. Transactions of the Institute of British Geographers, N.S. 4,4, 550-558.

Langton, J., (1972), Potentialities and problems of adopting a systems approach to the study of change in human geography. Progress in Geography, 4, 125-79.

Lebel, J.D., (1982), System Dynamics. In Progress in modelling and simulation, ed. F.E. Cellier (London, Academic Press).

Legasto, A.A., Forrester, J.W. and Lyneis, J.M. (eds.), (1980) System dynamics Vol.14, TIMS Studies in Management Science (North-Holland, Amsterdam).

Loogman, J.G., Samson, J. and Mur, L.R., (1979), The use of experimental ecology in simulating algal blooms. In State-of-the-Art in Ecological Modelling, ed. J.E. Jorgensen (Pergamon Press, Oxford).

Madden, M. and Moffatt, I., (1979), The Modelling of Migration in Urban and Regional Systems. In Deker, L., Savastone, Vansteenkiste, G.C. (eds.) Simulation of Systems, pp.115-125 (North-Holland, Amsterdam).

Malthus, T.R., (1976), An Essay on the Principle of Population (London, Pelican).

May, R.M., (1976), Simple mathematical models with very complicated dynamics, Nature, 2-61, 459-67.

Meadows, D.H., Meadows, D.L., Randers, J. and Behrens III W.W., (1972), The Limits to Growth (Universe Books, New York).

Meadows, D.L. Behrens III, W.W., Meadows, D.H. Nail, R.F., Randers, J. and Zahm E.K., (1974) *The Dynamics of Growth in a Finite World* (MIT Press, Cambridge, Massachusetts).

Moffatt, I., (1983), Some methodological and epistemological problems involved in system dynamics modelling. In *The 1983 International System Dynamics conference*, eds., J.D.-W. Morecroft, D.F. Andersen and J.D. Sterman (MIT., Massachusetts).

Moffatt, I., (1985), A conceptual framework for modelling the dynamics of environmental systems. in *Proceedings of 11th IMAC World Congress in System Simulation and Scientific Computation*, Vol.4, 225-229 (Oslo, Norway).

Myers, N., Nath, U.R. and Westlake, M., (1985), *The Gaia Atlas of planet management*. (London, Pan Books).

Naess, A., (1977), The Shallow and the deep, long range ecology movement: a summary. *Inquiry*, 16, 95-100.

Naylor, T.H. and Finger, J.M. (1971) *Validation*. In *Computer Simulation Experiments with models of economic systems*. ed., T.H. Naylor (New York, John Wiley).

Niall, R.F., (1976) *COALI: Dartmouth Energy Policy Model* (Unpublished Ph.D. Thesis, Dartmouth College).

Nordhaus, W.D., (1973), World Dynamics: measurement without data. *The Economic Journal*, 83, 1156-83.

Oerlemans, T.W., Tellings, M.M.J. and De Vries, H., (1972), World Dynamics: Social Feedbacks may give hope for the future, *Nature*, 238, 251-255.

Pepper, D., (1984), *The roots of modern environmentalism* (Croom Helm, London).

Poston, T. and Stewart, I.N., (1978), *Catastrophe theory and its applications* (Pitman, London).

Prigogine, I., Nicolis, G. and Babloyantz, A. (1972), Thermodynamics of evolution, *Physics Today*, November, 23-8; December, 24-6.

Pringle, D.G., (1980), Causal modelling: the Simon Blalock approach: *CATMOG 27* (Geo. Abstracts, Norwich).

Pugh, A.L., (1976), *DYNAMO User's Manual* (MIT Press, Cambridge, Massachusetts).

Pugh, A.L., (1980), Integration method: Euler or other for system dynamics. In *System Dynamics*, eds., A.A. Legasto, J.W. Forrester and J.M. Lyneis (North-Holland Publishing Company, Amsterdam).

Rademaker, O., (1974), The behaviour of pollution in Forrester's World model. In *Systems Analysis and Modelling Approaches in Environment Systems*, ed. R.M. Dmowski, (Institute of Applied Cybernetics, Polish Academy of Science).

Randers, J., (ed.) (1980), *Elements of the System Dynamics Method* (MIT Press, Cambridge, Massachusetts).

Randers, J. (1980), Guidelines for Model conceptualization. In *Elements of the System Dynamics Method*, ed. J. Randers. (MIT Press, Cambridge, Massachusetts).

Sagoff, M. (1985), Fact and value in ecological science. *Environmental Ethics* 7, 2, 99-116.

Schroeder, W.W., Sweeney, R.E. and Alfeld, L.E., (eds.), (1975), *Readings in Urban Dynamics* (Vol.2), (Wright-Allen Press, Cambridge, Massachusetts).

Senge, P.M., (1977), Statistical estimation of feedback models *Simulation* 28, 177-184.

Sterman, J.D., (1983), Appropriate summary statistics for evaluating the historical fit of system dynamics models. In *The 1983 International System Dynamics Conference Plenary Session Papers*, eds., J.D.W. Morecroft, D.F. Andersen and J.D. Sterman. MIT Cambridge, Massachusetts).

Stewart, C.O. and Ratnatunga, A.K., (1977), *DYSMAP Users Manual*. University of Bradford, England.

Tank-Neilson, C., (1980), Sensitivity analysis in system dynamics. In *Elements of the System Dynamics Method*, ed., J. Randers (MIT Press, Cambridge, Massachusetts).

Theil, H., (1966), *Applied economic forecasting*. (North-Holland, Amsterdam).

Thomas, R.W. and Huggett, R.J., (1980), *Modelling in geography a mathematical approach* (Harper and Row, London).

Tomlinson, R. and Kiss, I. (eds.), (1984) *Rethinking the process of operational research and system analysis* (Pergamon, Oxford).

Tomovic, R. and Vukobratovic, M., (1972), *General sensitivity theory* (Elsevier, New York).

Vermeulen, P.J. and De Lough, D.C.J., (1977), Growth in a finite world - a comprehensive sensitivity analysis. *Automatica*, 13, 77-84.

Wilson, A.G., (1970), Book review of *Urban Dynamics* by J.W. Forrester, *Environment and Planning*, 2, 3, 364-65.

- Wilson, A.G., (1981a), Catastrophe theory and bifurcation: Applications to urban and regional systems (Croom Helm, London).
- Wilson, A.G., (1981b), Geography and the Environment: Systems Analytical Methods (John Wiley and Sons, London).
- Wilson, A.G. and Kirkby, M.J., (1980), Mathematics for geographers and planners (Oxford University Press, Oxford).
- Wolstenholme, E.F., (1985), A Methodology for Qualitative System Dynamics. In Proceedings of the 1985 International Conference of the System Dynamics Society, eds., D.F. Andersen, N.B. Forrester and M.E. Warkentin.
- Zenner, A., (1980), "Comment on Forrester's 'Information Sources for modelling the national economy'". Journal of the American Statistical Association, 75, 371, September, 567-69.

## Listing of Catmogs in print

30:	Silk, The analysis of variance.	3.50
	Thomas, Information statistics in geography.	3.00
32:	Kellerman, Centographic measures in geography.	3.00
33:	Haynes, An introduction to dimensional analysis for geographers.	3.00
34:	Beaumont & Gatrell, An introduction to Q-analysis.	3.50
35:	The agricultural census - United Kingdom and United States.	3.00
36:	Aplin, Order-neighbour analysis.	3.00
37:	Johnston & Semple, Classification using information statistics.	3.00
38:	Openshaw, The modifiable areal unit problem.	3.00
39:	Dixon & Leach, Survey research in underdeveloped countries.	5.00
40:	Clark, Innovation diffusion: contemporary geographical approaches.	3.00
41:	Kirby, Choice in field surveying.	3.00
42:	Pickles, An introduction to likelihood analysis.	4.00
43:	Dewdney, the UK census of population 1981.	5.00
44:	Pickles, Geography and humanism.	3.00
45:	Boots, Voronoi (Thiessen) polygons.	3.50
46:	Fotheringham & Knudsen, Goodness-of-fit statistics.	3.50
47:	Goodchild, Spatial autocorrelation.	3.50
48:	Tinkler, Introductory matrix algebra.	4.00
49:	Sibley, Spatial applications of exploratory data analysis.	3.00
50:	Coshall, The application of nonparametric statistical tests in geography	7.50
51:	O'Brien, The statistical analysis of contingency table designs	3.50
52:	Bracken, Higgs, Martin and Webster, A classification of geographical information systems literature and applications	5.00
53:	Beaumont, An introduction to market analysis	3.50
54:	Jones, Multi-level models for geographical research	3.00
	Further titles in preparation	

**Order (including standing orders) from:** Environmental Publications,  
University of East Anglia,  
Norwich NR4 7TJ,

**Prices include postage**